

**GENERAL NOTES:**

1. STORM PANEL SHOWN ON THIS PRODUCT EVALUATION DOCUMENT (P.E.D.) HAS BEEN VERIFIED FOR COMPLIANCE IN ACCORDANCE WITH THE **2020 (7th EDITION)** OF THE FLORIDA BUILDING CODE.

DESIGN WIND LOADS SHALL BE DETERMINED AS PER SECTION 1620 OF THE ABOVE MENTIONED CODE, FOR A WIND SPEED AS REQUIRED BY THE JURISDICTION WHERE THESE SHUTTERS WILL BE INSTALLED AND FOR A DIRECTIONALITY FACTOR  $K_d=0.85$ . USING **ASCE 7-16** SHALL NOT EXCEED THE MAXIMUM (A.S.D.) DESIGN PRESSURE RATINGS INDICATED ON SHEETS 4 THRU 9.

IN ORDER TO VERIFY THE ABOVE CONDITION, ULTIMATE DESIGN WIND LOADS DETERMINED PER **ASCE 7-16** SHALL BE FIRST REDUCED TO A.S.D. DESIGN WIND LOADS BY MULTIPLYING THEM BY 0.6 IN ORDER TO COMPARE THESE W/ MAX. (A.S.D.) DESIGN PRESSURE RATINGS INDICATED ON SHEETS 4 THRU 9.

IN ORDER TO VERIFY THAT COMPONENTS AND ANCHORS ON THIS P.E.D. AS TESTED WERE NOT OVER STRESSED, A 33% INCREASE IN ALLOWABLE STRESS FOR WIND LOADS WAS **NOT** USED IN THEIR ANALYSIS. A DURATION FACTOR  $CD=1.60$  WAS USED FOR VERIFICATION OF FASTENERS IN WOOD.

STORM PANEL'S ADEQUACY FOR IMPACT AND FATIGUE RESISTANCE HAS BEEN VERIFIED IN ACCORDANCE WITH SECTION **1626** OF THE ABOVE MENTIONED CODE AS PER AMERICAN TEST LAB REPORTS # 0425.01-00 AND # 0616.01-05, PER PROTOCOLS TAS-201, TAS-202 AND TAS-203.

2. ALL STEEL SHEET METAL PANELS SHALL HAVE STRUCTURAL QUALITY ASTM A653 SQ, GRADE 40, WITH G-90 GALVANIZED STEEL DESIGNATION &  $F_y=52.3$  ksi. (AFTER ROLLED)
3. ALL ALUMINUM EXTRUSIONS SHALL BE ALUMINUM ASSOCIATION 6063-T6 ALLOY & TEMPER UNLESS OTHERWISE NOTED. ALL ALUMINUM EXTRUSIONS IN CONTACT WITH DISSIMILAR MATERIALS SHALL COMPLY WITH SECTION III-6 OF THE 2015 ALUMINUM DESIGN MANUAL.
4. ALL SCREWS TO BE STAINLESS STEEL 304 OR 316 AISI SERIES OR CORROSION RESISTANT COATED CARBON STEEL AS PER DIN 50018 W/ 50 ksi YIELD STRENGTH AND 90 ksi TENSILE STRENGTH & SHALL COMPLY W/ FLORIDA BUILDING CODE **SECTION 2411.3.3.4.**
5. BOLTS TO BE ASTM A-307 GALVANIZED STEEL, OR AISI 304 SERIES STAINLESS STEEL, WITH 36 ksi MINIMUM YIELD STRENGTH.
6. ANCHORS TO WALL SHALL BE AS FOLLOWS: (UNLESS OTHERWISE NOTED).
  - (A) TO EXISTING POURED CONCRETE ( $f'_c=3$  ksi):
    - 1/4"  $\phi$  TAPCONS & MAXI-SET TAPCONS AS MANUFACTURED BY I.T.W./BUILDEX.
    - 1/4"  $\phi$  CRETE-FLEX SS4 ANCHORS AS MANUFACTURED BY ELCO CONSTRUCTION PRODUCTS.
    - 1/4"  $\phi$  x 7/8" CALK-IN ANCHORS, 1/4"  $\phi$  ELCO male & female "PANELMATE" OR 1/4"  $\phi$  ELCO male "PANELMATE PLUS" AS MANUFACTURED BY DEWALT, INC. AND ELCO CONSTRUCTION PRODUCTS, RESPECTIVELY.
    - 1/4"  $\phi$  x 3/4" ALL POINTS SOLID-SET ANCHORS AS DISTRIBUTED BY ALL POINTS SCREW, BOLT & SPECIALTY COMPANY.

**NOTES:**

- A.1) MINIMUM EMBEDMENT INTO POURED CONCRETE OF TAPCON ANCHOR OR CRETE-FLEX SS4 ANCHORS IS 1 3/4", FOR ELCO PANELMATES IS 2", FOR ELCO male "PANELMATE PLUS" IS 2".
- A.2) 7/8" CALK-IN ANCHORS SHALL BE ENTIRELY EMBEDDED INTO THE POURED CONCRETE. NO EMBEDMENT INTO STUCCO SHALL BE PERMITTED. 1/4"  $\phi$ -20 SCREWS USED SHALL BE 1 1/2" LONG MINIMUM SHOULD STUCCO EXIST, AND 1" MINIMUM FOR WALLS WITH NO STUCCO.
- A.3) MINIMUM EMBEDMENT OF 1/4"  $\phi$  x 3/4" ALL POINTS SOLID-SET ANCHORS SHALL BE 7/8" INTO THE POURED CONCRETE. NO EMBEDMENT INTO STUCCO SHALL BE PERMITTED. 1/4"  $\phi$ -20 S.S. MACHINE SCREW USED SHALL BE 1 1/2" LONG MINIMUM SHOULD STUCCO EXIST, AND 1" MINIMUM FOR WALLS WITH NO STUCCO.
- A.4) IN CASE THAT PRECAST STONE, PRECAST CONCRETE PANELS, OR PAVERS BE FOUND ON THE EXISTING WALL OR FLOOR, ANCHORS SHALL BE LONG ENOUGH TO REACH THE MAIN STRUCTURE BEHIND SUCH PANELS, ANCHORAGE SHALL BE AS INDICATED ON NOTES A.1) & A.2) ABOVE.

- (B) TO EXISTING CONCRETE BLOCK WALL (ASTM C-90):
  - 1/4"  $\phi$  TAPCONS & MAXI-SET TAPCONS AS MANUFACTURED BY I.T.W./BUILDEX.
  - 1/4"  $\phi$  CRETE-FLEX SS4 ANCHORS AS MANUFACTURED BY ELCO CONSTRUCTION PRODUCTS.
  - 1/4"  $\phi$  x 7/8" CALK-IN ANCHORS OR 1/4"  $\phi$  ELCO male & female "PANELMATE" OR
  - 1/4"  $\phi$  ELCO male "PANELMATE PLUS" AS MANUFACTURED BY DEWALT, INC. AND ELCO CONSTRUCTION PRODUCTS, RESPECTIVELY.
  - 3/8"  $\phi$  RED HEAD DYNABOLT SLEEVE ANCHORS AS MANUFACTURED BY I.T.W. BUILDEX.
  - 1/4"  $\phi$  x 3/4" ALL POINTS SOLID-SET ANCHORS AS DISTRIBUTED BY ALL POINTS SCREW, BOLT & SPECIALTY COMPANY.

**NOTES:**

- B.1) MINIMUM EMBEDMENT OF TAPCON ANCHORS, ELCO PANELMATE, ELCO male "PANELMATE PLUS", RED HEAD DYNABOLT AND CRETE-FLEX SS4, INTO THE CONCRETE BLOCK UNIT SHALL BE 1 1/4".
  - B.2) 7/8" CALK-IN ANCHORS SHALL BE ENTIRELY EMBEDDED INTO THE CONCRETE BLOCK UNIT. NO EMBEDMENT INTO STUCCO SHALL BE PERMITTED. 1/4"  $\phi$ -20 SCREWS USED SHALL BE 1 1/2" LONG MINIMUM SHOULD STUCCO EXIST, AND 1" MINIMUM FOR WALLS WITH NO STUCCO.
  - B.3) MINIMUM EMBEDMENT OF 1/4"  $\phi$  x 3/4" ALL POINTS SOLID-SET ANCHORS SHALL BE 7/8" INTO THE CONCRETE BLOCK. NO EMBEDMENT INTO STUCCO SHALL BE PERMITTED. 1/4"  $\phi$ -20 S.S. MACHINE SCREW USED SHALL BE 1 1/2" LONG MINIMUM SHOULD STUCCO EXIST, AND 1" MINIMUM FOR WALLS WITH NO STUCCO.
  - B.4) IN CASE THAT PRECAST STONE OR PRECAST CONCRETE PANELS BE FOUND ON THE EXISTING WALL, ANCHORS SHALL BE LONG ENOUGH TO REACH THE MAIN STRUCTURE BEHIND SUCH PANELS. ANCHORAGE SHALL BE AS INDICATED ON NOTES IN B.1) & B.2) ABOVE.
- (C) ANCHORS SHALL BE INSTALLED FOLLOWING ALL OF THE RECOMMENDATIONS AND SPECIFICATIONS OF THE ANCHOR'S MANUFACTURER.
7. PANELS MAY ALSO BE INSTALLED HORIZONTALLY FOLLOWING INSTALLATION DETAILS SHOWN ON SECTIONS 1 THRU 8 (SHEET 2 & 3 OF 9) EXCEPT THAT HEADERS 2, 3 & 4 SHALL NOT BE USED.
  8. IT SHALL BE THE RESPONSIBILITY OF THE CONTRACTOR TO VERIFY THE SOUNDNESS OF THE STRUCTURE WHERE SHUTTER IS TO BE ATTACHED TO INSURE PROPER ANCHORAGE. THIS SHUTTER SHALL ONLY BE ATTACHED TO CONCRETE, BLOCK OR WOOD FRAME BUILDINGS.
  9. THE INSTALLATION CONTRACTOR IS TO SEAL/CAULK ALL SHUTTER COMPONENT EDGES WHICH REMAIN IN CONTINUOUS CONTACT WITH THE BUILDING TO PREVENT WIND/RAIN INTRUSION. CAULK AND SEAL SHUTTER TRACKS ALL AROUND FULL LENGTH.
  10. STORM PANEL INSTALLATION SHALL COMPLY WITH SPECS INDICATED IN THIS DRAWING PLUS ANY BUILDING AND ZONING REGULATIONS PROVIDED BY THE JURISDICTION WHERE PERMIT IS APPLIED TO.
  11. (a) THIS PRODUCT EVALUATION DOCUMENT (P.E.D.) PREPARED BY THIS ENGINEER IS GENERIC AND DOES NOT PROVIDE INFORMATION FOR A SITE SPECIFIC PROJECT; I.E. WHERE THE SITE CONDITIONS DEVIATE FROM THE P.E.D.
    - (b) CONTRACTOR TO BE RESPONSIBLE FOR THE SELECTION, PURCHASE AND INSTALLATION INCLUDING LIFE SAFETY OF THIS PRODUCT BASED ON THIS P.E.D. PROVIDED HE/SHE DOES NOT DEVIATE FROM THE CONDITIONS DETAILED ON THIS DOCUMENT. CONSTRUCTION SAFETY AT SITE IS THE CONTRACTOR'S RESPONSIBILITY.
    - (c) THIS PRODUCT EVALUATION DOCUMENT WILL BE CONSIDERED INVALID IF MODIFIED.
    - (d) SITE SPECIFIC PROJECTS SHALL BE PREPARED BY A FLORIDA REGISTERED ENGINEER OR ARCHITECT WHICH WILL BECOME THE ENGINEER OF RECORD (E.O.R.) FOR THE PROJECT AND WHO WILL BE RESPONSIBLE FOR THE PROPER USE OF THE P.E.D. ENGINEER OF RECORD, ACTING AS A DELEGATED ENGINEER TO THE P.E.D. ENGINEER, SHALL SUBMIT TO THIS LATTER THE SITE SPECIFIC DRAWINGS FOR REVIEW.
    - (e) THIS P.E.D. SHALL BEAR THE DATE AND ORIGINAL SEAL AND SIGNATURE OF THE PROFESSIONAL ENGINEER OF RECORD THAT PREPARED IT.
  12. SHUTTER MANUFACTURER'S LABEL SHALL BE LOCATED ON A READILY VISIBLE LOCATION AT STORM PANEL IN ACCORDANCE WITH SECTION **1709.9.3** OF FLORIDA BUILDING CODE. ONE LABEL SHALL BE PLACED FOR EVERY OPENING. LABELING TO COMPLY WITH SECTION **1709.9.2** OF THE FLORIDA BUILDING CODE.

**THIS DRAWING SHALL ONLY BE USED TO OBTAIN PERMITS IN THE STATE OF FLORIDA**

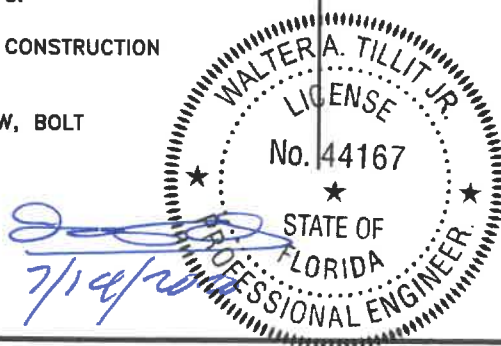

**FLORIDA BUILDING CODE (High Velocity Hurricane Zone)**

© 2020 TILTECO, INC.		<b>0.030" THICK GALVANIZED BERTHA STEEL STORM PANEL (2.25" DEEP)</b>		M.P. DRAWN BY:	
<p>TILLIT TESTING &amp; ENGINEERING COMPANY 6355 N.W. 36th St., Ste. 305, VIRGINIA GARDENS, FL 33166 Phone: (305)871-1530 Fax: (305)871-1531 CA-0006719 WALTER A. TILLIT Jr. P.E. FLORIDA Lic. # 44167</p>		<p><b>EASTERN METAL SUPPLY, INC</b> 4268 WEST ROADS DRIVE WEST PALM BEACH, FL 33407 PHONE: (561)533-6061 FAX: (561)588-4780</p>		7/9/2020 DATE:	
				<p><b>20-185</b> DRAWING No</p>	
REV. NO	DESCRIPTION	DATE	REV. No	DESCRIPTION	DATE
1	OLD 17-098	7/9/2020	3		
2			4		

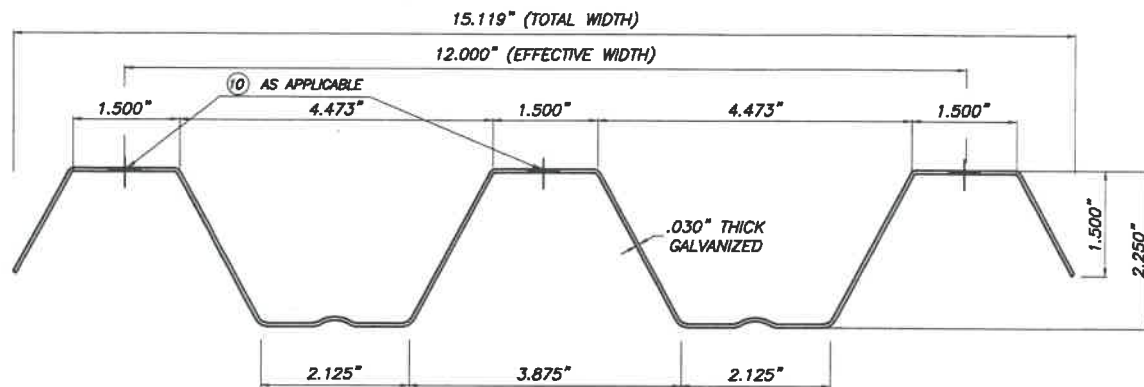

**1 PANEL**  
SCALE: 3/8" = 1"

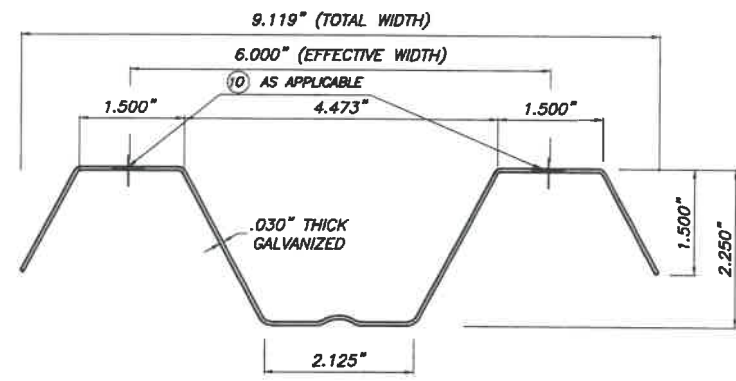

**1A HALF PANEL**  
SCALE: 3/8" = 1"

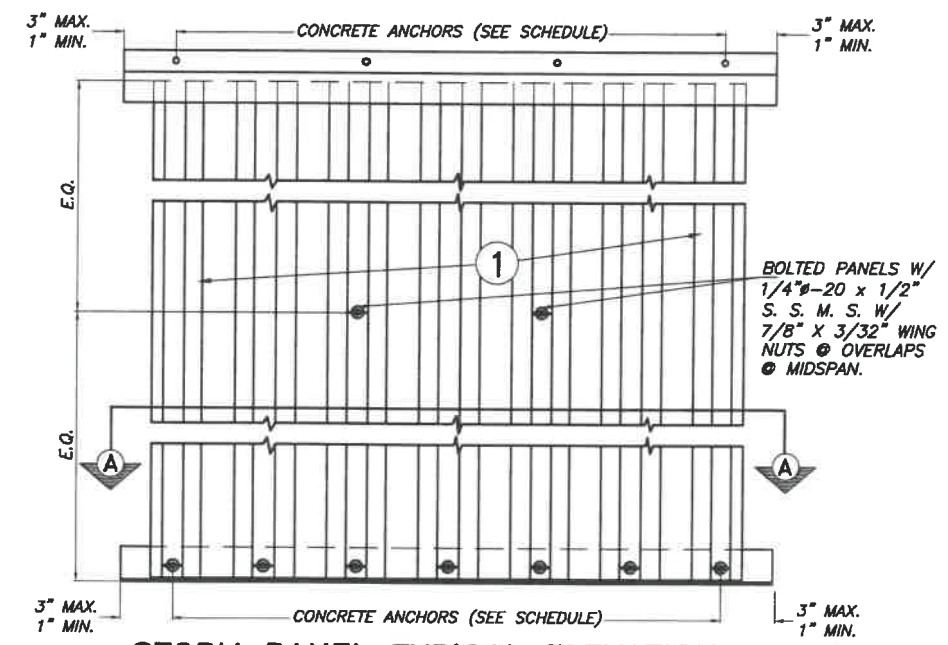

**STORM PANEL TYPICAL ELEVATION**  
N. T. S.

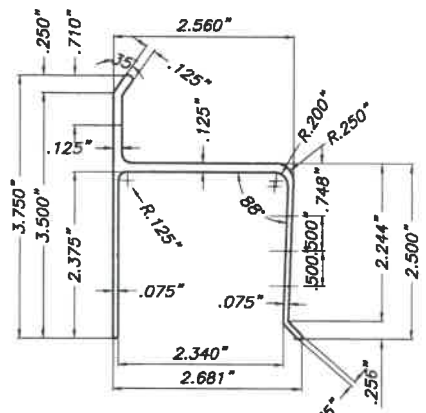
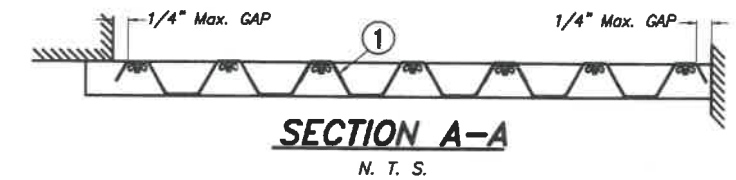

**2 'h' HEADER**  
SCALE: 3/8" = 1"

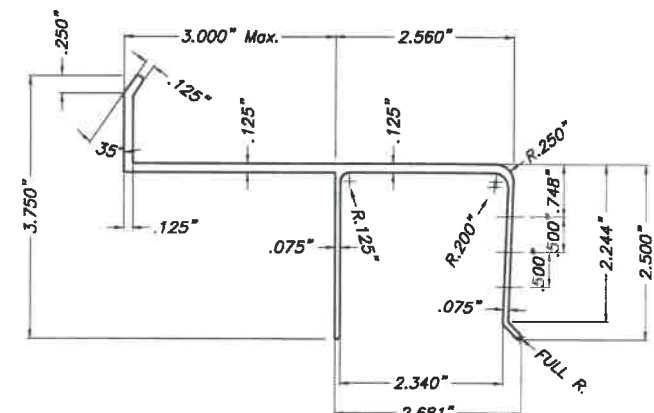

**3 3" Max. 'U' BUILD OUT**  
SCALE: 3/8" = 1"

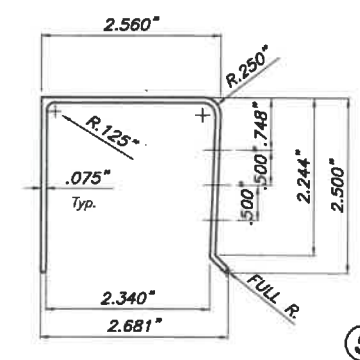

**4 'U' HEADER**  
SCALE: 3/8" = 1"

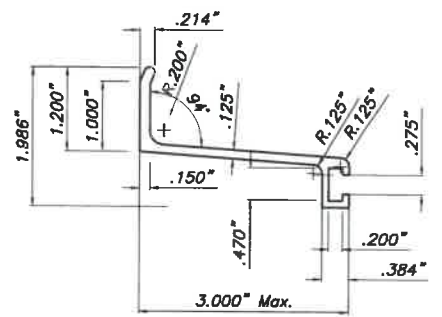

**5 3" ANGLE BUILD OUT BRACKET**  
SCALE: 3/8" = 1"

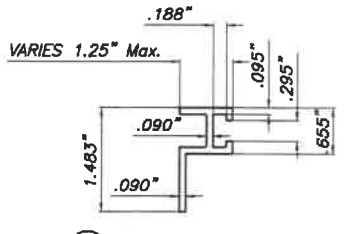

**6 'F' TRACK**  
SCALE: 3/8" = 1"

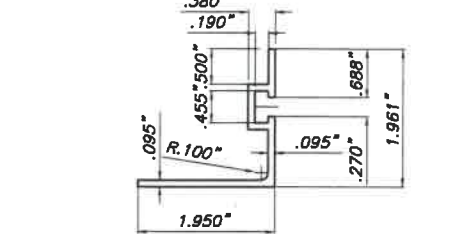

**7 REVERSED 'F' ANGLE TRACK**  
SCALE: 3/8" = 1"

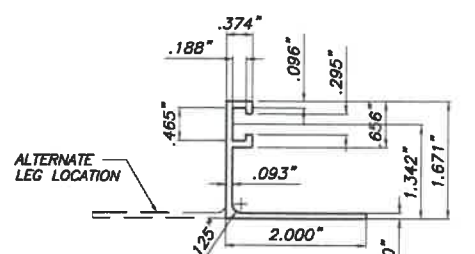

**8 'F' TRACK ANGLE**  
SCALE: 3/8" = 1"

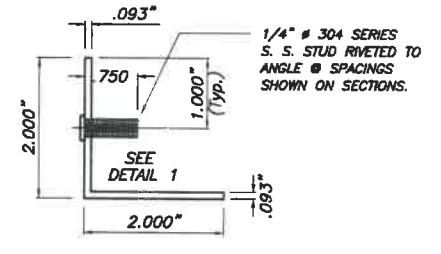

**9 STUDDED ANGLE**  
SCALE: 3/8" = 1"

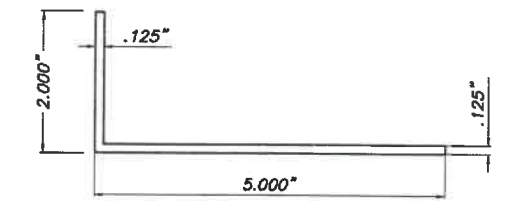

**12 2" x 5" (Max.) x .125" ANGLE**  
SCALE: 3/8" = 1"

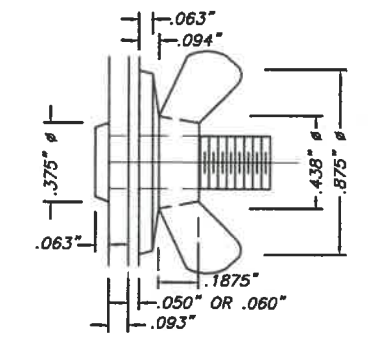

**DETAIL 1: STUD W/ DIE CAST ZINC NICKEL PLATED WING NUT**

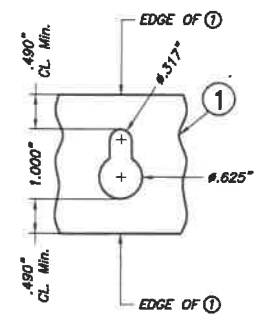

**OPTION 1**

**10 KEY HOLE AT PANEL**

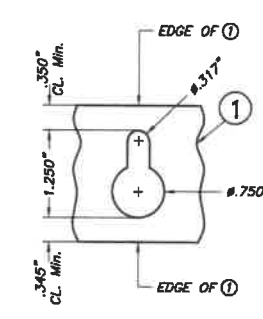

**OPTION 2**

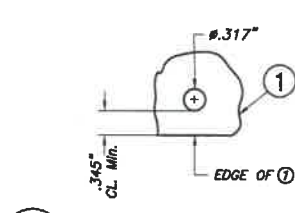

**10A ROUND HOLE AT PANEL (OPTION TO 10)**

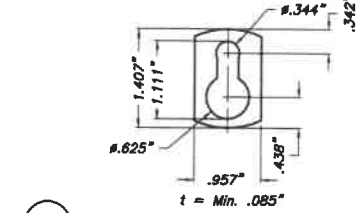

**11 KEY HOLE WASHER**  
3105-H154 Alum. ALLOY  
SCALE: 3/8" = 1"

**COMPONENTS**

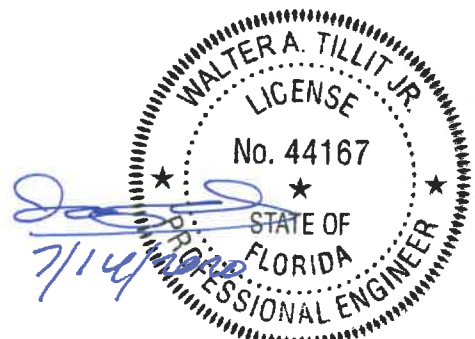

© 2020 TILTECO, INC.

**TILTECO INC.**

TILLIT TESTING & ENGINEERING COMPANY  
6355 N.W. 36th St., Ste. 305, VIRGINIA GARDENS, FL 33166  
Phone: (305)871-1530 Fax: (305)871-1531  
CA-0006719  
WALTER A. TILLIT Jr. P.E.  
FLORIDA Lic. # 44167

**FLORIDA BUILDING CODE (High Velocity Hurricane Zone)**

**0.030" THICK GALVANIZED BERTHA STEEL STORM PANEL (2.25" DEEP)**

**EASTERN METAL SUPPLY, INC**  
4268 WEST ROADS DRIVE  
WEST PALM BEACH, FL 33407  
PHONE: (561)533-6061  
FAX: (561)588-4780

M.P.  
DRAWN BY:  
7/9/2020  
DATE:  
**20-185**  
DRAWING No  
SHEET 1A OF 9

REV. NO	DESCRIPTION	DATE	REV. No	DESCRIPTION	DATE
1	OLD 17-098	7/9/2020	3		
2			4		

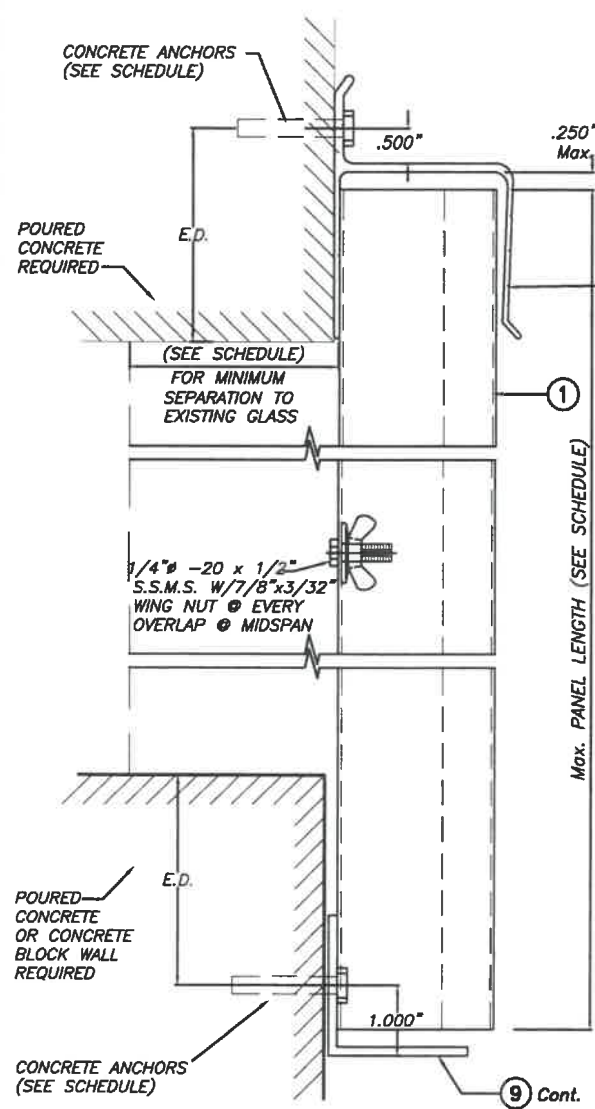

SECTION @ ANCHOR

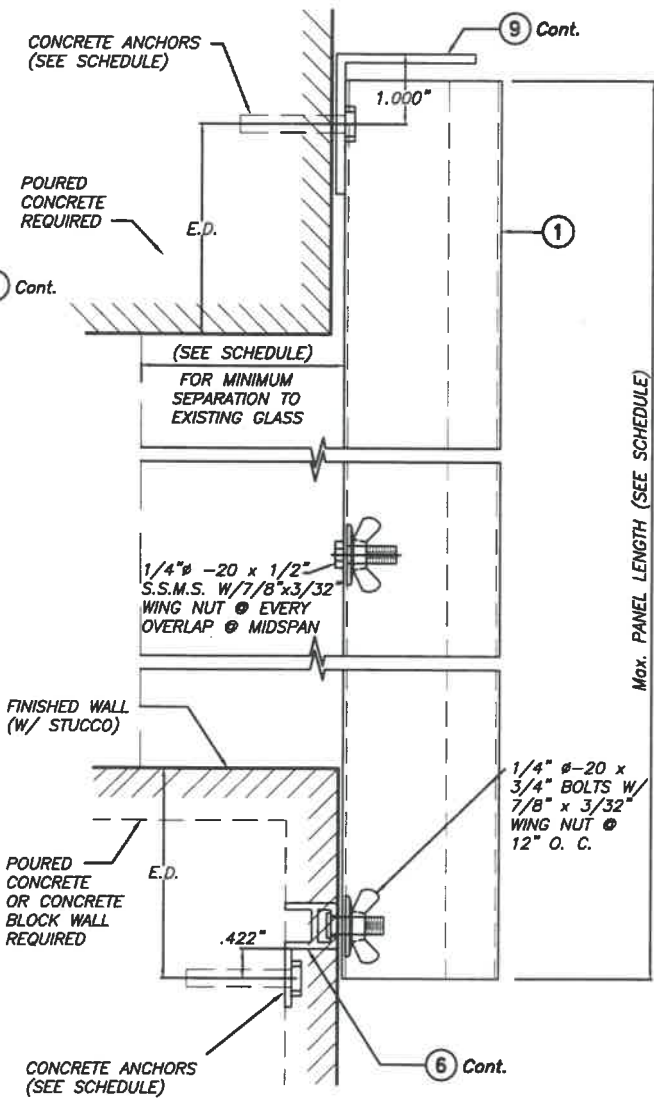

**WALL MOUNTING INSTALLATION SECTION 2**  
SCALE : 3/8" = 1"

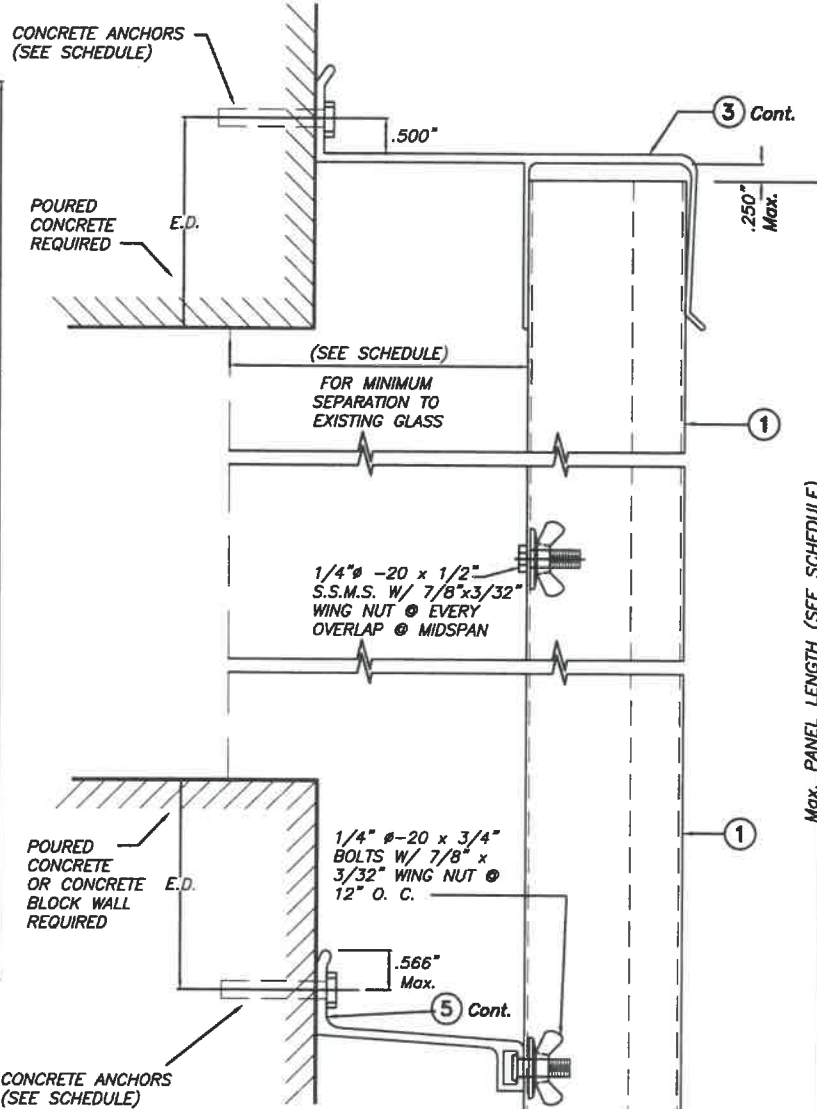

**BUILD OUT INSTALLATION SECTION 3**  
SCALE : 3/8" = 1"

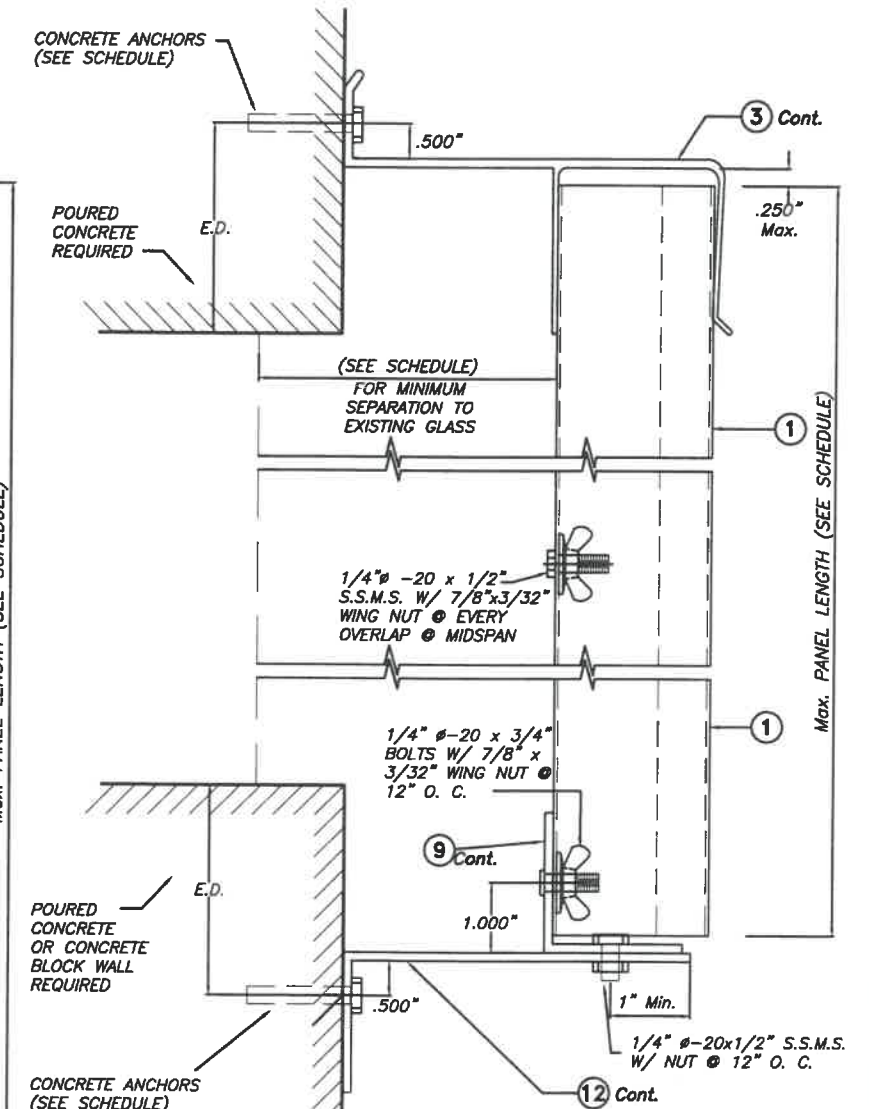

**BUILD OUT INSTALLATION SECTION 4**  
SCALE : 3/8" = 1"

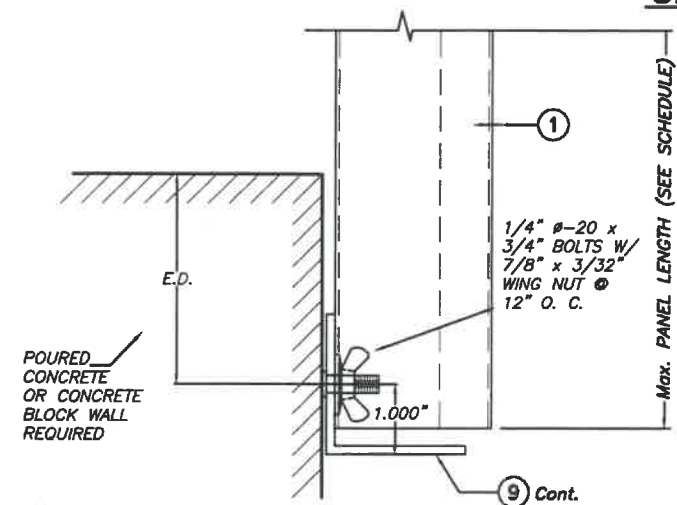

SECTION @ STUD

**WALL MOUNTING INSTALLATION SECTION 1**  
SCALE : 3/8" = 1"

NOTE : DETAIL OF SECTION @ STUD VALID ALSO FOR WALL MOUNTING INSTALLATION - SECTION 2 (TOP)

E. D. = EDGE DISTANCE  
(SEE SCHEDULE ON SHEET 5, 6 & 7 OF 9)

NOTE FOR COMBINATION OF SECTIONS :  
WALL/FLOOR/CEILING MOUNTING SECTIONS CAN BE COMBINED IN ANY WAY TO SUIT ANY INSTALLATION.

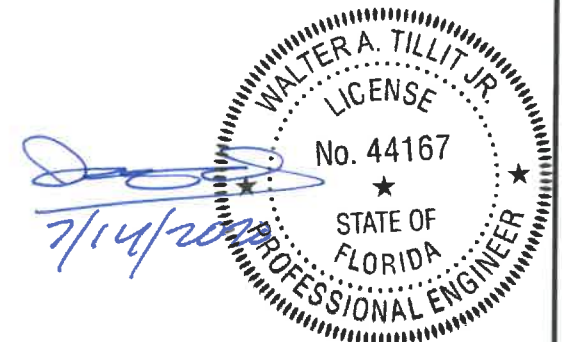

FLORIDA BUILDING CODE (High Velocity Hurricane Zone)

<p>© 2020 TILTECO, INC.</p> <p><b>TILTECO INC.</b></p> <p>TILLIT TESTING &amp; ENGINEERING COMPANY 6355 N.W. 36th St., Ste. 305, VIRGINIA GARDENS, FL 33166 Phone : (305)871-1530 . Fax : (305)871-1531 CA-0006719 WALTER A. TILLIT Jr. P.E. FLORIDA Lic. # 44167</p>		<p><b>0.030" THICK GALVANIZED BERTHA STEEL STORM PANEL (2.25" DEEP)</b></p> <p><b>EASTERN METAL SUPPLY, INC</b> 4268 WEST ROADS DRIVE WEST PALM BEACH, FL 33407 PHONE: (561)533-6061 FAX: (561)588-4780</p>	<p>M.P. DRAWN BY:</p> <p>7/9/2020 DATE:</p> <p><b>20-185</b> DRAWING No</p>		
REV. NO	DESCRIPTION	DATE	REV. No	DESCRIPTION	DATE
1	OLD 17-099	7/9/2020	3		
2			4		

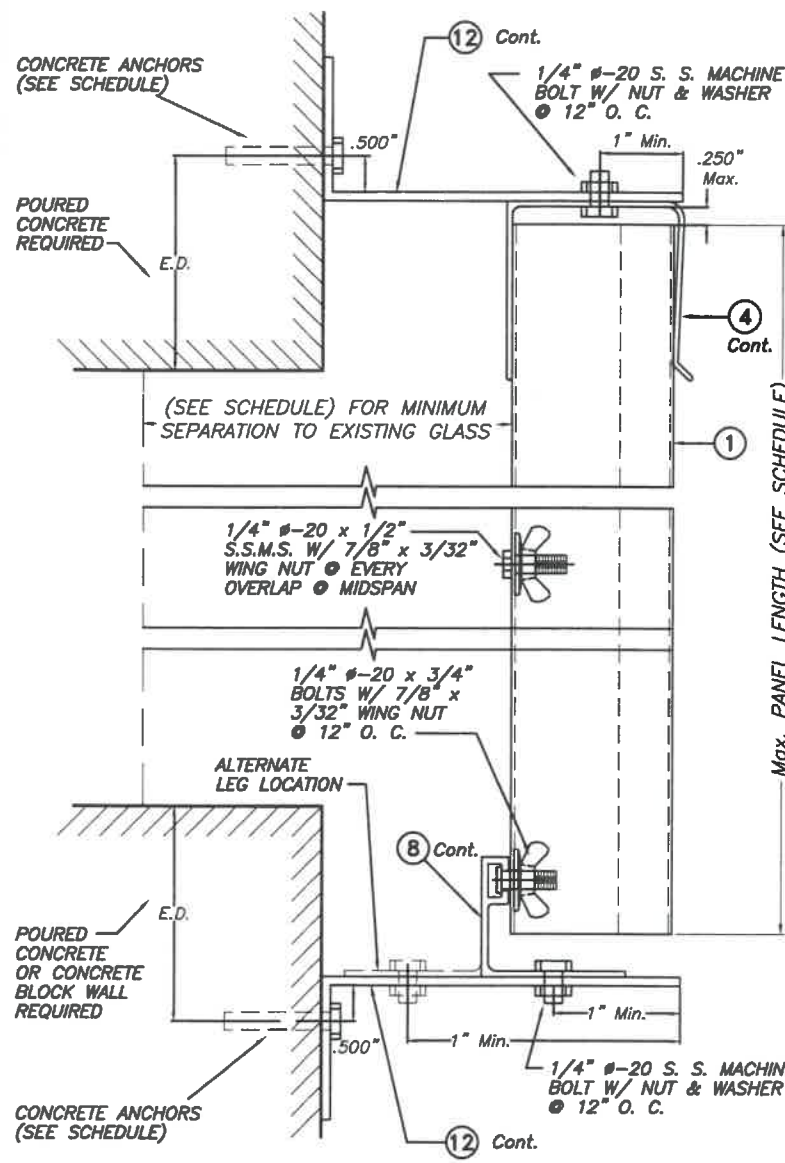

**BUILD OUT INSTALLATION**  
**- SECTION 5**

SCALE : 3/8" = 1"

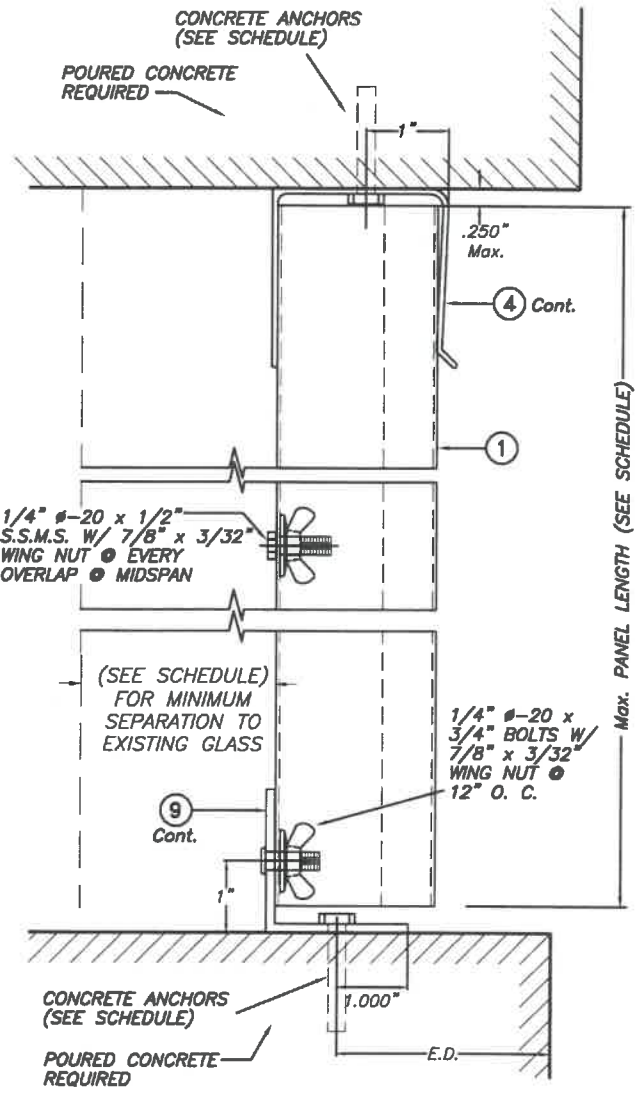

**CEILING & FLOOR MOUNTING**  
**INSTALLATION - SECTION 6**

SCALE : 3/8" = 1"

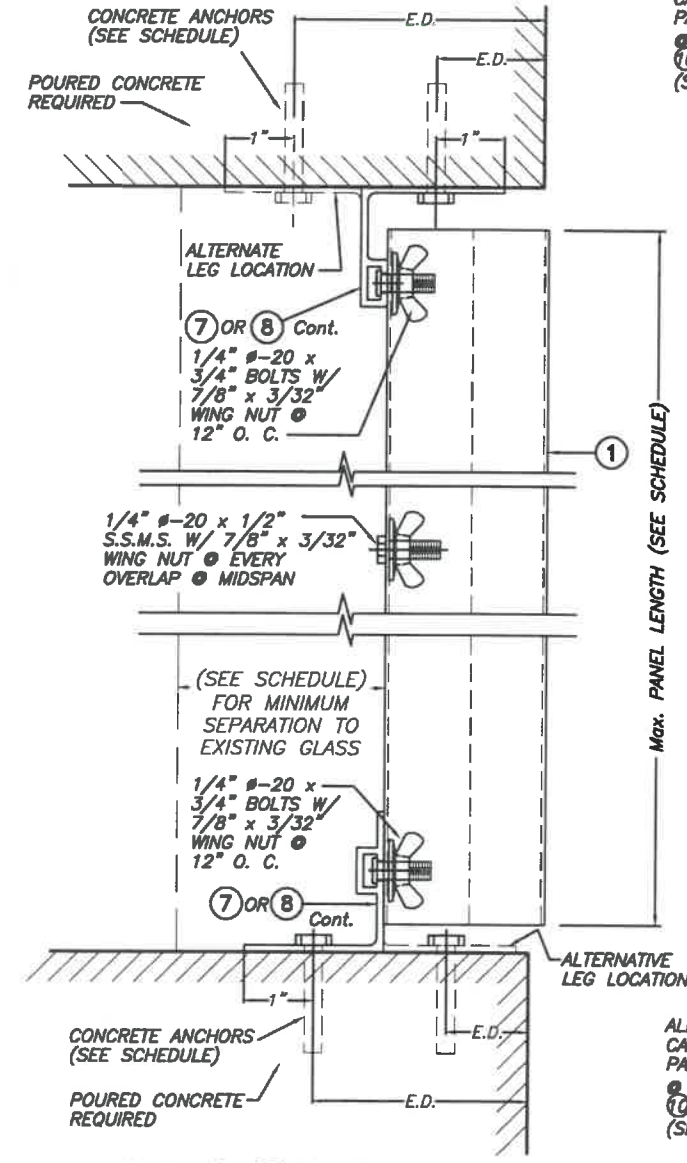

**CEILING & FLOOR MOUNTING**  
**INSTALLATION - SECTION 7**

SCALE : 3/8" = 1"

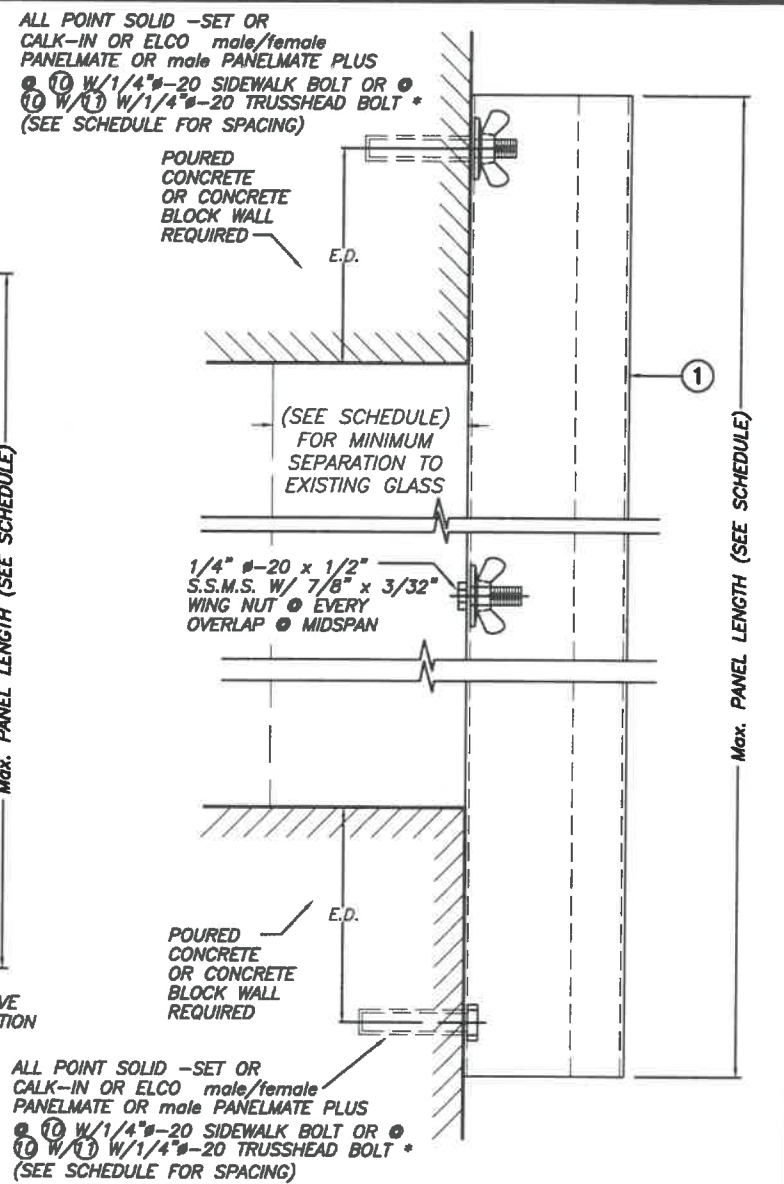

**WALL MOUNTING INSTALLATION (D. M.)**  
**- SECTION 8**

SCALE : 3/8" = 1"

ALL POINT SOLID -SET OR  
 CALK-IN OR ELCO male/female  
 PANELMATE OR male PANELMATE PLUS  
 10 W/1/4"-20 SIDEWALK BOLT OR  
 11 W/1/4"-20 TRUSSHEAD BOLT \*  
 (SEE SCHEDULE FOR SPACING)

ALL POINT SOLID -SET OR  
 CALK-IN OR ELCO male/female  
 PANELMATE OR male PANELMATE PLUS  
 10 W/1/4"-20 SIDEWALK BOLT OR  
 11 W/1/4"-20 TRUSSHEAD BOLT \*  
 (SEE SCHEDULE FOR SPACING)

E. D. = EDGE DISTANCE  
 (SEE SCHEDULE ON  
 SHEET 5, 6 & 7 OF 9)

NOTE FOR COMBINATION OF SECTIONS :  
 WALL/FLOOR/CEILING MOUNTING SECTIONS CAN BE  
 COMBINED IN ANY WAY TO SUIT ANY INSTALLATION.

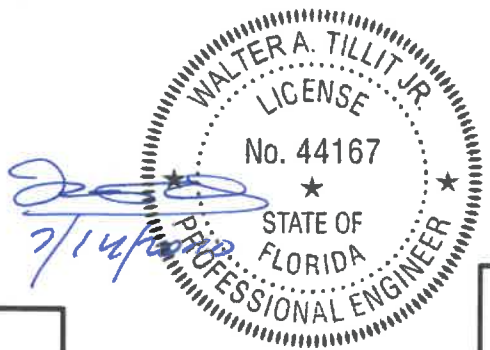

\*  
 SIDE WALK BOLTS ARE 3/4"x3/32" THICK  
 HEAD MACHINE SCREW W/LENGTH  
 AS PER NOTES A.2 & B.2 (SHEET 1)  
 \*  
 TRUSS HEAD BOLTS ARE 1/2"x1/8" THICK  
 HEAD MACHINE SCREW W/LENGTH  
 AS PER NOTES A.2 & B.2 (SHEET 1)

© 2020 TILTECO, INC.

**TILTECO INC.**

TILLIT TESTING & ENGINEERING COMPANY  
 6355 N.W. 36th St., Ste. 305, VIRGINIA GARDENS, FL 33166  
 Phone : (305)871-1530 • Fax : (305)871-1531  
 CA-0006719  
 WALTER A. TILLIT Jr. P.E.  
 FLORIDA Lic. # 44167

**FLORIDA BUILDING CODE (High Velocity Hurricane Zone)**

**0.030" THICK GALVANIZED BERTHA STEEL STORM PANEL (2.25" DEEP)**

M.P.  
 DRAWN BY:  
 7/9/2020  
 DATE:  
**20-185**  
 DRAWING No  
 SHEET 3 OF 9

REV. NO	DESCRIPTION	DATE	REV. No	DESCRIPTION	DATE
1	OLD 17-098	7/9/2020	3		
2			4		

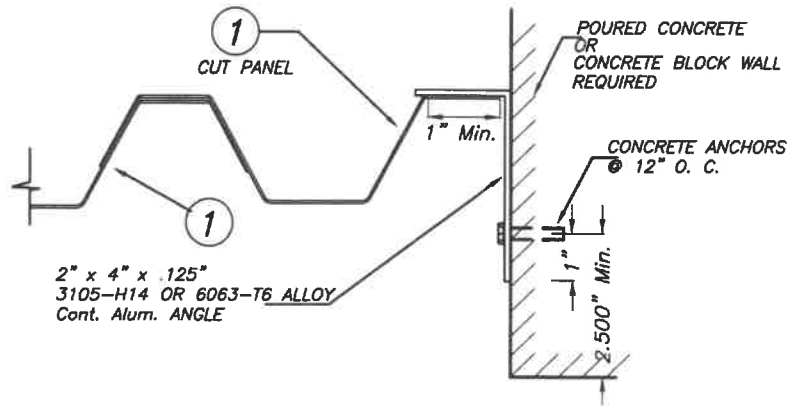

**CASE A (Plan)**

SCALE: 1/4" = 1"

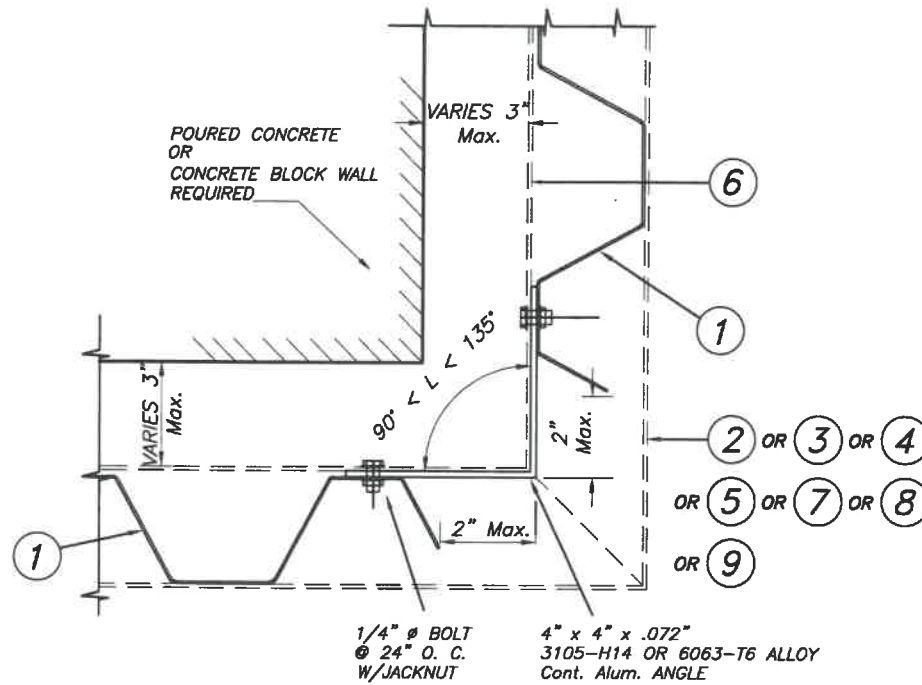

**CASE B (Plan)**

SCALE: 1/4" = 1"

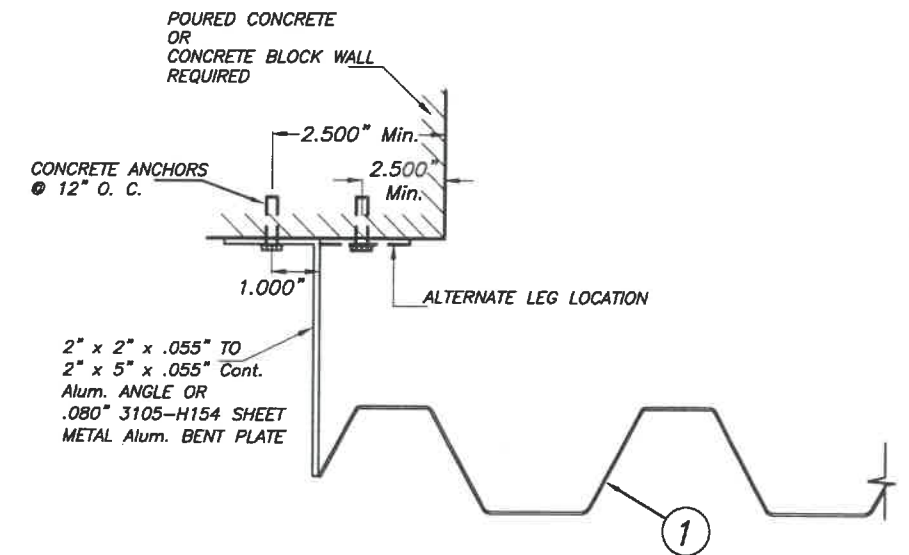

**CASE C (Plan)**

SCALE: 1/4" = 1"

**END CLOSURES DETAILS**

**MAXIMUM A.S.D. DESIGN PRESSURE RATING (p.s.f.) AND CORRESPONDING MAXIMUM PANEL LENGTH "L" SCHEDULE**

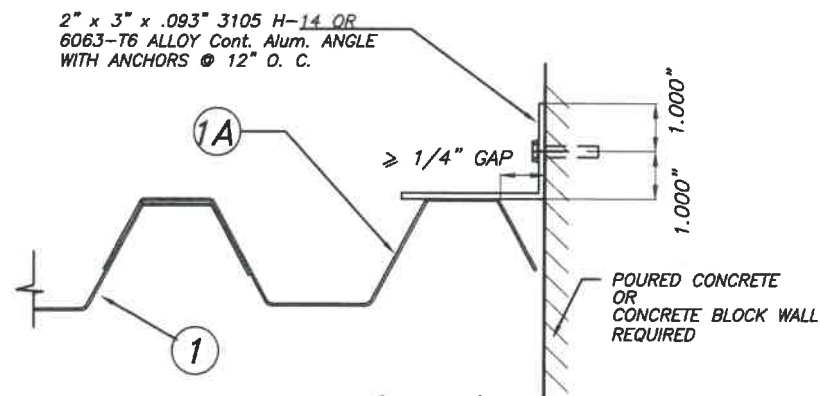

**CASE D (Plan)**

SCALE: 1/4" = 1"

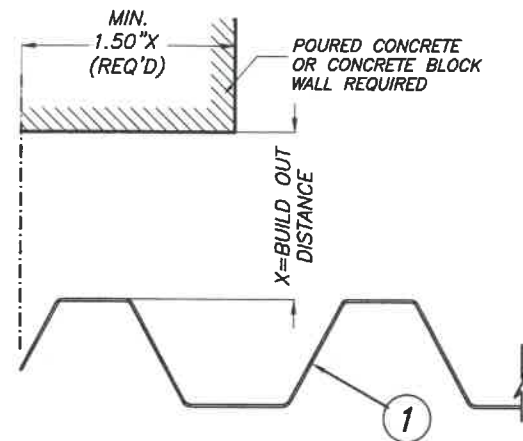

**CASE E (Plan)**

SCALE: 1/4" = 1"

MAXIMUM A.S.D. DESIGN PRESSURE RATING (p.s.f.)	Max. PANEL LENGTH L (ft.) (SEE SECTIONS)	MINIMUM SEPARATION TO GLASS	APPLICABLE TO SECTIONS # & ANY COMBINATION OF THEM
+66.0, -76.0	7'-6" OR LESS	3"	1,2,3,4,5 & 8
+60.0, -70.0	>7'-6" TO 8'-6"	3"	1,2,3,4,5 & 8
+66.0, -76.0	7'-6" OR LESS	3 3/4"	6 & 7
+60.0, -70.0	>7'-6" TO 8'-6"	3 3/4"	6 & 7

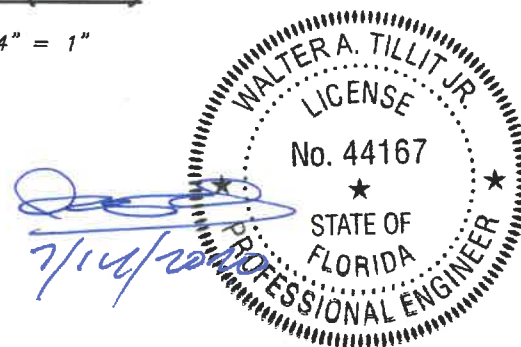

© 2020 TILTECO, INC.

**TILTECO INC.**

TILLIT TESTING & ENGINEERING COMPANY  
 6355 N.W. 36th St., Ste. 305, VIRGINIA GARDENS, FL 33166  
 Phone: (305)871-1530 Fax: (305)871-1531  
 CA-0006719  
 WALTER A. TILLIT Jr. P.E.  
 FLORIDA Lic. # 44167

**FLORIDA BUILDING CODE (High Velocity Hurricane Zone)**

**0.030" THICK GALVANIZED BERTHA STEEL STORM PANEL (2.25" DEEP)**

**EASTERN METAL SUPPLY, INC**

4268 WEST ROADS DRIVE  
 WEST PALM BEACH, FL. 33407  
 PHONE: (561)533-6061  
 FAX: (561)588-4780

M.P.  
DRAWN BY:

7/9/2020  
DATE:

**20-185**

DRAWING No

REV. NO	DESCRIPTION	DATE	REV. No	DESCRIPTION	DATE
1	OLD 17-099	7/9/2020	3		
2			4		

SHEET 4 OF 9

MAXIMUM A.S.D. DESIGN PRESSURE RATING (p.s.f.)	MAXIMUM ANCHORS SPACING FOR E. D. = 3 1/2" **														APPLICABLE TO SECTIONS # & ANY COMBINATION OF THEM	MAXIMUM PANEL LENGTH "L" (ft.)
	L.T.W. BUILDEX				ELCO CONSTRUCTION PRODUCTS						DEWALT, INC.		ALL POINTS			
	TAPCONS/MAXI-SET TAPCONS		RED HD SLEEVE		CRETE-FLEX SS4		MALE/FEMALE PANELMATE		MALE PANELMATE PLUS		CALK-IN		SOLID-SET			
	TO CONCRETE	TO BLOCK	TO CONCRETE	TO BLOCK	TO CONCRETE	TO BLOCK	TO CONCRETE	TO BLOCK	TO CONCRETE	TO BLOCK	TO CONCRETE	TO BLOCK	TO CONCRETE	TO BLOCK		
+60.0, -61.5	12"	N/A	N/A	N/A	12"	N/A	12"	N/A	12"	N/A	12"	N/A	N/A	N/A	1 (TOP)	6'-0" OR LESS
	12"	7"	N/A	12"	12"	12"	12"	12"	12"	11"	12"	11"	12"	12"	1 (BOTTOM)	
	12"	N/A	N/A	N/A	12"	N/A	12"	N/A	12"	N/A	12"	N/A	12"	12"	2 (TOP)	
	12"	7"	N/A	12"	12"	12"	12"	12"	12"	11"	12"	11"	N/A	N/A	2 (BOTTOM)	
	12"	N/A	N/A	N/A	12"	N/A	12"	N/A	12"	N/A	12"	N/A	N/A	N/A	3 (TOP)	
	12"	7"	N/A	12"	12"	12"	12"	12"	12"	11"	12"	11"	N/A	N/A	3 (BOTTOM)	
	12"	N/A	N/A	N/A	12"	N/A	12"	N/A	12"	N/A	12"	N/A	N/A	N/A	4 (TOP)	
	12"	7"	N/A	12"	12"	12"	12"	12"	12"	11"	12"	11"	N/A	N/A	4 (BOTTOM)	
	12"	N/A	N/A	N/A	12"	N/A	12"	N/A	12"	N/A	12"	N/A	N/A	N/A	5 (TOP)	
	12"	7"	N/A	12"	12"	12"	12"	12"	12"	10"	12"	10"	N/A	N/A	5 (BOTTOM)	
	12"	N/A	N/A	N/A	12"	N/A	12"	N/A	12"	N/A	12"	N/A	N/A	N/A	6 (TOP)	
	12"	N/A	N/A	N/A	12"	N/A	12"	N/A	12"	N/A	12"	N/A	N/A	N/A	6 (BOTTOM)	
12"	N/A	N/A	N/A	12"	N/A	12"	N/A	12"	N/A	11"	N/A	N/A	N/A	7 (TOP/BOTTOM)		
N/A	N/A	N/A	N/A	N/A	N/A	12"	12"	12"	12"	12"	11"	12"	12"	8 (TOP/BOTTOM)		

MAXIMUM A.S.D. DESIGN PRESSURE RATING (p.s.f.)	MAXIMUM ANCHORS SPACING FOR E. D. = 3 1/2" **														APPLICABLE TO SECTIONS # & ANY COMBINATION OF THEM	MAXIMUM PANEL LENGTH "L" (ft.)
	L.T.W. BUILDEX				ELCO CONSTRUCTION PRODUCTS						DEWALT, INC.		ALL POINTS			
	TAPCONS/MAXI-SET TAPCONS		RED HD SLEEVE		CRETE-FLEX SS4		MALE/FEMALE PANELMATE		MALE PANELMATE PLUS		CALK-IN		SOLID-SET			
	TO CONCRETE	TO BLOCK	TO CONCRETE	TO BLOCK	TO CONCRETE	TO BLOCK	TO CONCRETE	TO BLOCK	TO CONCRETE	TO BLOCK	TO CONCRETE	TO BLOCK	TO CONCRETE	TO BLOCK		
+66.0, -72.0	12"	N/A	N/A	N/A	12"	N/A	12"	N/A	12"	N/A	12"	N/A	N/A	N/A	1 (TOP)	6'-0" OR LESS
	12"	6"	N/A	12"	12"	12"	12"	11"	12"	10"	12"	9"	12"	12"	1 (BOTTOM)	
	12"	N/A	N/A	N/A	12"	N/A	12"	N/A	12"	N/A	12"	N/A	12"	12"	2 (TOP)	
	12"	6"	N/A	12"	12"	12"	12"	11"	12"	10"	12"	9"	N/A	N/A	2 (BOTTOM)	
	12"	N/A	N/A	N/A	12"	N/A	12"	N/A	12"	N/A	12"	N/A	N/A	N/A	3 (TOP)	
	12"	6"	N/A	12"	12"	12"	12"	11"	12"	10"	12"	9"	N/A	N/A	3 (BOTTOM)	
	12"	N/A	N/A	N/A	12"	N/A	12"	N/A	12"	N/A	12"	N/A	N/A	N/A	4 (TOP)	
	12"	6"	N/A	12"	12"	12"	12"	11"	12"	10"	12"	9"	N/A	N/A	4 (BOTTOM)	
	12"	N/A	N/A	N/A	12"	N/A	12"	N/A	12"	N/A	12"	N/A	N/A	N/A	5 (TOP)	
	12"	4"	N/A	12"	12"	9"	12"	8"	12"	7"	12"	6"	N/A	N/A	5 (BOTTOM)	
	12"	N/A	N/A	N/A	12"	N/A	12"	N/A	12"	N/A	12"	N/A	N/A	N/A	6 (TOP)	
	12"	N/A	N/A	N/A	12"	N/A	12"	N/A	12"	N/A	11"	N/A	N/A	N/A	6 (BOTTOM)	
10"	N/A	N/A	N/A	12"	N/A	12"	N/A	12"	N/A	9"	N/A	N/A	N/A	7 (TOP/BOTTOM)		
N/A	N/A	N/A	N/A	N/A	N/A	12"	11"	12"	6"	12"	9"	12"	12"	8 (TOP/BOTTOM)		

MAXIMUM A.S.D. DESIGN PRESSURE RATING (p.s.f.)	MAXIMUM ANCHORS SPACING FOR E. D. = 3 1/2" **														APPLICABLE TO SECTIONS # & ANY COMBINATION OF THEM	MAXIMUM PANEL LENGTH "L" (ft.)
	L.T.W. BUILDEX				ELCO CONSTRUCTION PRODUCTS						DEWALT, INC.		ALL POINTS			
	TAPCONS/MAXI-SET TAPCONS		RED HD SLEEVE		CRETE-FLEX SS4		MALE/FEMALE PANELMATE		MALE PANELMATE PLUS		CALK-IN		SOLID-SET			
	TO CONCRETE	TO BLOCK	TO CONCRETE	TO BLOCK	TO CONCRETE	TO BLOCK	TO CONCRETE	TO BLOCK	TO CONCRETE	TO BLOCK	TO CONCRETE	TO BLOCK	TO CONCRETE	TO BLOCK		
+60.0, -61.5	12"	N/A	N/A	N/A	12"	N/A	12"	N/A	12"	N/A	12"	N/A	N/A	N/A	1 (TOP)	>6'-0" TO 7'-6"
	12"	6"	N/A	12"	12"	12"	12"	10"	12"	8"	12"	9"	12"	12"	1 (BOTTOM)	
	12"	N/A	N/A	N/A	12"	N/A	12"	N/A	12"	N/A	12"	N/A	12"	12"	2 (TOP)	
	12"	6"	N/A	12"	12"	12"	12"	10"	12"	9"	12"	9"	N/A	N/A	2 (BOTTOM)	
	12"	N/A	N/A	N/A	12"	N/A	12"	N/A	12"	N/A	12"	N/A	N/A	N/A	3 (TOP)	
	12"	6"	N/A	12"	12"	12"	12"	10"	12"	9"	12"	9"	N/A	N/A	3 (BOTTOM)	
	12"	N/A	N/A	N/A	12"	N/A	12"	N/A	12"	N/A	12"	N/A	N/A	N/A	4 (TOP)	
	12"	6"	N/A	12"	12"	12"	12"	10"	12"	9"	12"	9"	N/A	N/A	4 (BOTTOM)	
	12"	N/A	N/A	N/A	12"	N/A	12"	N/A	12"	N/A	12"	N/A	N/A	N/A	5 (TOP)	
	12"	4"	N/A	11"	12"	8"	12"	7"	12"	6"	12"	6"	N/A	N/A	5 (BOTTOM)	
	12"	N/A	N/A	N/A	12"	N/A	12"	N/A	12"	N/A	12"	N/A	N/A	N/A	6 (TOP)	
	11"	N/A	N/A	N/A	12"	N/A	12"	N/A	12"	N/A	12"	N/A	N/A	N/A	6 (BOTTOM)	
9"	N/A	N/A	N/A	12"	N/A	12"	N/A	12"	N/A	12"	N/A	N/A	N/A	7 (TOP/BOTTOM)		
N/A	N/A	N/A	N/A	N/A	N/A	12"	10"	12"	6"	12"	9"	12"	12"	8 (TOP/BOTTOM)		

**MAXIMUM A.S.D. DESIGN PRESSURE RATING (p.s.f.) AND CORRESPONDING MAXIMUM ANCHOR SPACING SCHEDULE FOR INSTALLATIONS INTO CONCRETE AND CONCRETE BLOCK STRUCTURES \***

\*\* MAXIMUM ANCHOR SPACINGS ARE VALID FOR 3 1/2" EDGE DISTANCE. FOR E. D. LESS THAN 3 1/2", REDUCE ANCHOR SPACING BY MULTIPLYING SPACING SHOWN ON SCHEDULE BY THE FOLLOWING FACTORS. (NOTE : Min. E. D. FOR CALK-IN ANCHORS IS 2 1/2"). FOR THIS OPERATION TO BE POSSIBLE, REDUCED SPACING OBTAINED USING FACTOR SHALL NOT BE LESS THAN MINIMUM SPACING INDICATED FOR EACH ANCHOR TYPE AT ANCHORS LEGEND.

ACTUAL E. D.	FACTOR			
	TAPCON/CRETE-FLEX SS4/PANELMATES	CALK-IN	SOLID-SET	RED HD. SLEEVE
3"	-	.75	.78	1.00
2 1/2"	-	.50	-	1.00
2"	-	-	-	0.88
1 1/2"	.35	-	-	-

**ANCHORS LEGEND**

ANCHORS TYPE	ANCHOR MIN. SPACING
TAPCON/PANELMATES	4.0"
CALK-IN	2.5"
SOLID-SET	3.5"
3/8"Ø RED HD. DYNABOLT SLEEVE	4.5"
CRETE FLEX SS4	6.0"

E. D. = EDGE DISTANCE

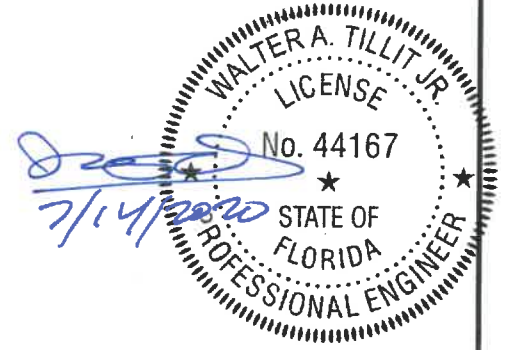

\*SEE NOTES ON SHEET 8 & 9 OF 9 FOR ANCHOR TYPES & SPACING FOR INSTALLATIONS INTO WOOD FRAME BUILDINGS.

© 2020 TILTECO, INC.	<b>TILTECO inc.</b>	<b>FLORIDA BUILDING CODE (High Velocity Hurricane Zone)</b>	<b>0.030" THICK GALVANIZED BERTHA STEEL STORM PANEL (2.25" DEEP)</b>	M.P. DRAWN BY:	
TILLIT TESTING & ENGINEERING COMPANY 6355 N.W. 36th St., Ste. 305, VIRGINIA GARDENS, FL 33186 Phone : (305)871-1530 Fax : (305)871-1531 CA-0006719		EASTERN METAL SUPPLY, INC 4268 WEST ROADS DRIVE WEST PALM BEACH, FL 33407 PHONE: (561)533-6061 FAX: (561)588-4780		7/9/2020 DATE:	
WALTER A. TILLIT Jr. P.E. FLORIDA Lic. # 44167				<b>20-185</b> DRAWING No	
REV. NO	DESCRIPTION	DATE	REV. No	DESCRIPTION	DATE
1	OLD 17-098	7/9/2020	5		
2			4		

SHEET 5 OF 9

MAXIMUM A.S.D. DESIGN PRESSURE RATING (p.s.f.)	MAXIMUM ANCHORS SPACING FOR E. D. = 3 1/2" **																APPLICABLE TO SECTIONS # & ANY COMBINATION OF THEM	MAXIMUM PANEL LENGTH "L" (ft.)
	I.T.W. BUILDEX				ELCO CONSTRUCTION PRODUCTS						DEWALT, INC		ALL PONTS					
	TAPCONS/MAXI-SET TAPCONS		RED HD SLEEVE		CRETE-FLEX SS4		MALE/FEMALE PANELMATE		MALE PANELMATE PLUS		CALK-IN		SOLID-SET					
	TO CONCRETE	TO BLOCK	TO CONCRETE	TO BLOCK	TO CONCRETE	TO BLOCK	TO CONCRETE	TO BLOCK	TO CONCRETE	TO BLOCK	TO CONCRETE	TO BLOCK	TO CONCRETE	TO BLOCK				
+66.0, -72.0	12"	N/A	N/A	N/A	12"	N/A	12"	N/A	12"	N/A	12"	N/A	N/A	N/A	1 (TOP)	>6'-0" TO 7'-6"		
	12"	5"	N/A	12"	12"	10"	12"	9"	12"	8"	12"	7"	12"	12"	1 (BOTTOM)			
	12"	N/A	N/A	N/A	12"	N/A	12"	N/A	12"	N/A	12"	N/A	12"	12"	2 (TOP)			
	12"	5"	N/A	12"	12"	10"	12"	9"	12"	8"	12"	7"	N/A	N/A	2 (BOTTOM)			
	12"	N/A	N/A	N/A	12"	N/A	12"	N/A	12"	N/A	12"	N/A	N/A	N/A	3 (TOP)			
	12"	5"	N/A	12"	12"	10"	12"	9"	12"	8"	12"	7"	N/A	N/A	3 (BOTTOM)			
	12"	N/A	N/A	N/A	12"	N/A	12"	N/A	12"	N/A	12"	N/A	N/A	N/A	4 (TOP)			
	12"	5"	N/A	12"	12"	10"	12"	9"	12"	8"	12"	7"	N/A	N/A	4 (BOTTOM)			
	12"	N/A	N/A	N/A	12"	N/A	12"	N/A	12"	N/A	12"	N/A	N/A	N/A	5 (TOP)			
	11"	N/A	N/A	8"	12"	6"	12"	5"	12"	4"	11"	4"	N/A	N/A	5 (BOTTOM)			
12"	N/A	N/A	N/A	12"	N/A	12"	N/A	12"	N/A	11"	N/A	N/A	N/A	6 (TOP)				
9"	N/A	N/A	N/A	12"	N/A	12"	N/A	12"	N/A	8"	N/A	N/A	N/A	6 (BOTTOM)				
8"	N/A	N/A	N/A	11"	N/A	12"	N/A	10"	N/A	7"	N/A	N/A	N/A	7 (TOP/BOTTOM)				
N/A	N/A	N/A	N/A	N/A	N/A	6"	9"	12"	6"	12"	7"	12"	12"	8 (TOP/BOTTOM)				
+60.0, -61.5	12"	N/A	N/A	N/A	12"	N/A	12"	N/A	12"	N/A	12"	N/A	N/A	N/A	1 (TOP)	>7'-6" TO 8'-6"		
	12"	5"	N/A	12"	12"	11"	12"	9"	12"	8"	12"	8"	12"	12"	1 (BOTTOM)			
	12"	N/A	N/A	N/A	12"	N/A	12"	N/A	12"	N/A	12"	N/A	12"	12"	2 (TOP)			
	12"	5"	N/A	12"	12"	11"	12"	9"	12"	8"	12"	8"	N/A	N/A	2 (BOTTOM)			
	12"	N/A	N/A	N/A	12"	N/A	12"	N/A	12"	N/A	12"	N/A	N/A	N/A	3 (TOP)			
	12"	5"	N/A	12"	12"	11"	12"	9"	12"	8"	12"	8"	N/A	N/A	3 (BOTTOM)			
	12"	N/A	N/A	N/A	12"	N/A	12"	N/A	12"	N/A	12"	N/A	N/A	N/A	4 (TOP)			
	12"	5"	N/A	12"	12"	11"	12"	9"	12"	8"	12"	8"	N/A	N/A	4 (BOTTOM)			
	12"	N/A	N/A	N/A	12"	N/A	12"	N/A	12"	N/A	12"	N/A	N/A	N/A	5 (TOP)			
	12"	N/A	N/A	9"	12"	6"	12"	5"	12"	4"	12"	4"	N/A	N/A	5 (BOTTOM)			
9"	N/A	N/A	N/A	12"	N/A	12"	N/A	12"	N/A	11"	N/A	N/A	N/A	6 (TOP)				
12"	N/A	N/A	N/A	12"	N/A	12"	N/A	12"	N/A	9"	N/A	N/A	N/A	6 (BOTTOM)				
8"	N/A	N/A	N/A	11"	N/A	12"	N/A	11"	N/A	7"	N/A	N/A	N/A	7 (TOP/BOTTOM)				
N/A	N/A	N/A	N/A	N/A	N/A	12"	9"	12"	6"	12"	8"	12"	12"	8 (TOP/BOTTOM)				
+66.0, -72.0	12"	N/A	N/A	N/A	12"	N/A	12"	N/A	12"	N/A	12"	N/A	N/A	N/A	1 (TOP)	>7'-6" TO 8'-6"		
	12"	4"	N/A	12"	12"	9"	12"	8"	12"	7"	12"	6"	12"	12"	1 (BOTTOM)			
	12"	N/A	N/A	N/A	12"	N/A	12"	N/A	12"	N/A	12"	N/A	12"	12"	2 (TOP)			
	12"	4"	N/A	12"	12"	9"	12"	8"	12"	7"	12"	6"	N/A	N/A	2 (BOTTOM)			
	12"	N/A	N/A	N/A	12"	N/A	12"	N/A	12"	N/A	12"	N/A	N/A	N/A	3 (TOP)			
	12"	4"	N/A	12"	12"	9"	12"	8"	12"	7"	12"	6"	N/A	N/A	3 (BOTTOM)			
	12"	N/A	N/A	N/A	12"	N/A	12"	N/A	12"	N/A	12"	N/A	N/A	N/A	4 (TOP)			
	12"	4"	N/A	12"	12"	9"	12"	8"	12"	7"	12"	6"	N/A	N/A	4 (BOTTOM)			
	12"	N/A	N/A	N/A	12"	N/A	12"	N/A	12"	N/A	12"	N/A	N/A	N/A	5 (TOP)			
	9"	N/A	N/A	7"	12"	5"	12"	4"	12"	3"	9"	3"	N/A	N/A	5 (BOTTOM)			
11"	N/A	N/A	N/A	12"	N/A	12"	N/A	12"	N/A	10"	N/A	N/A	N/A	6 (TOP)				
8"	N/A	N/A	N/A	12"	N/A	11"	N/A	11"	N/A	7"	N/A	N/A	N/A	6 (BOTTOM)				
7"	N/A	N/A	N/A	9"	N/A	10"	N/A	9"	N/A	6"	N/A	N/A	N/A	7 (TOP/BOTTOM)				
N/A	N/A	N/A	N/A	N/A	N/A	12"	8"	12"	6"	12"	6"	12"	12"	8 (TOP/BOTTOM)				

**MAXIMUM A.S.D. DESIGN PRESSURE RATING (p.s.f.) AND CORRESPONDING MAXIMUM ANCHOR SPACING SCHEDULE FOR INSTALLATIONS INTO CONCRETE AND CONCRETE BLOCK STRUCTURES \***

\*\* MAXIMUM ANCHOR SPACINGS ARE VALID FOR 3 1/2" EDGE DISTANCE. FOR E. D. LESS THAN 3 1/2"; REDUCE ANCHOR SPACING BY MULTIPLYING SPACING SHOWN ON SCHEDULE BY THE FOLLOWING FACTORS. (NOTE : Min. E. D. FOR CALK-IN ANCHORS IS 2 1/2"). FOR THIS OPERATION TO BE POSSIBLE, REDUCED SPACING OBTAINED USING FACTOR SHALL NOT BE LESS THAN MINIMUM SPACING INDICATED FOR EACH ANCHOR TYPE AT ANCHORS LEGEND.

ACTUAL E. D.	FACTOR			
	TAPCON/ CRETE-FLEX SS4/ PANELMATES	CALK-IN	SOLID-SET	RED HD. SLEEVE
3"	-	.75	.78	1.00
2 1/2"	-	.50	-	1.00
2"	-	-	-	0.88
1 1/2"	.35	-	-	-

**ANCHORS LEGEND**

ANCHORS TYPE	ANCHOR MIN. SPACING
TAPCON/ PANELMATES	4.0"
CALK-IN	2.5"
SOLID-SET	3.5"
3/8"Ø RED HD. DYNABOLT SLEEVE	4.5"
CRETE FLEX SS4	6.0"

E. D. = EDGE DISTANCE

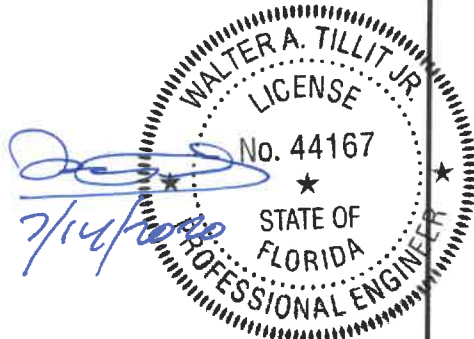

\*SEE NOTES ON SHEET 8 & 9 OF 9 FOR ANCHOR TYPES & SPACING FOR INSTALLATIONS INTO WOOD FRAME BUILDINGS.

**FLORIDA BUILDING CODE (High Velocity Hurricane Zone)**

 TILTECO INC. TILLIT TESTING & ENGINEERING COMPANY 6355 N.W. 36th St., Ste. 305, VIRGINIA GARDENS, FL 33166 Phone : (305)871-1530 . Fax : (305)871-1531 CA-0006719 WALTER A. TILLIT Jr. P.E. FLORIDA Lic. # 44167	© 2020 TILTECO, INC. <b>0.030" THICK GALVANIZED BERTHA STEEL STORM PANEL (2.25" DEEP)</b>	M.P. DRAWN BY:
	<b>EASTERN METAL SUPPLY, INC</b> 4268 WEST ROADS DRIVE WEST PALM BEACH, FL 33407 PHONE: (561)533-6061 FAX: (561)588-4780	7/9/2020 DATE:
REV. NO    DESCRIPTION    DATE    REV. No    DESCRIPTION    DATE 1    OLD 17-089    7/9/2020    3 2	<b>20-185</b> DRAWING No	SHEET 6 OF 9

MAXIMUM A.S.D. DESIGN PRESSURE RATING (p.s.f.)	MAXIMUM ANCHORS SPACING FOR E. D. = 3 1/2" **														APPLICABLE TO SECTIONS # & ANY COMBINATION OF THEM	MAXIMUM PANEL LENGTH "L" (ft.)
	L.T.W. BUILDING				ELCO CONSTRUCTION PRODUCTS						DEWALT, INC		ALL POINTS			
	TAPCONS/MAXI-SET TAPCONS		RED HD SLEEVE		CRETE-FLEX SS4		MALE/FEMALE PANELMATE		MALE PANELMATE PLUS		CALK-IN		SOLID-SET			
	TO CONCRETE	TO BLOCK	TO CONCRETE	TO BLOCK	TO CONCRETE	TO BLOCK	TO CONCRETE	TO BLOCK	TO CONCRETE	TO BLOCK	TO CONCRETE	TO BLOCK	TO CONCRETE	TO BLOCK		
+66.0, -76.0	12"	N/A	N/A	N/A	12"	N/A	12"	N/A	12"	N/A	12"	N/A	N/A	N/A	1 (TOP)	6'-0" OR LESS
	12"	6"	N/A	12"	12"	12"	12"	11"	12"	9"	12"	9"	12"	12"	1 (BOTTOM)	
	12"	N/A	N/A	N/A	12"	N/A	12"	N/A	12"	N/A	12"	N/A	12"	12"	2 (TOP)	
	12"	6"	N/A	12"	12"	12"	12"	11"	12"	9"	12"	9"	N/A	N/A	2 (BOTTOM)	
	12"	N/A	N/A	N/A	12"	N/A	12"	N/A	12"	N/A	12"	N/A	N/A	N/A	3 (TOP)	
	12"	6"	N/A	12"	12"	12"	12"	11"	12"	9"	12"	9"	N/A	N/A	3 (BOTTOM)	
	12"	N/A	N/A	N/A	12"	N/A	12"	N/A	12"	N/A	12"	N/A	N/A	N/A	4 (TOP)	
	12"	6"	N/A	12"	12"	12"	12"	11"	12"	9"	12"	9"	N/A	N/A	4 (BOTTOM)	
	12"	N/A	N/A	N/A	12"	N/A	12"	N/A	12"	N/A	12"	N/A	N/A	N/A	5 (TOP)	
	12"	4"	N/A	12"	12"	8"	12"	7"	12"	6"	12"	6"	N/A	N/A	5 (BOTTOM)	
	12"	N/A	N/A	N/A	12"	N/A	12"	N/A	12"	N/A	12"	N/A	N/A	N/A	6 (TOP)	
	11"	N/A	N/A	N/A	12"	N/A	12"	N/A	12"	N/A	10"	N/A	N/A	N/A	6 (BOTTOM)	
9"	N/A	N/A	N/A	12"	N/A	12"	N/A	12"	N/A	9"	N/A	N/A	N/A	7 (TOP/BOTTOM)		
N/A	N/A	N/A	N/A	N/A	N/A	12"	11"	12"	6"	12"	9"	12"	12"	8 (TOP/BOTTOM)		

MAXIMUM A.S.D. DESIGN PRESSURE RATING (p.s.f.)	MAXIMUM ANCHORS SPACING FOR E. D. = 3 1/2" **														APPLICABLE TO SECTIONS # & ANY COMBINATION OF THEM	MAXIMUM PANEL LENGTH "L" (ft.)
	L.T.W. BUILDING				ELCO CONSTRUCTION PRODUCTS						DEWALT, INC		ALL POINTS			
	TAPCONS/MAXI-SET TAPCONS		RED HD SLEEVE		CRETE-FLEX SS4		MALE/FEMALE PANELMATE		MALE PANELMATE PLUS		CALK-IN		SOLID-SET			
	TO CONCRETE	TO BLOCK	TO CONCRETE	TO BLOCK	TO CONCRETE	TO BLOCK	TO CONCRETE	TO BLOCK	TO CONCRETE	TO BLOCK	TO CONCRETE	TO BLOCK	TO CONCRETE	TO BLOCK		
+66.0, -76.0	12"	N/A	N/A	N/A	12"	N/A	12"	N/A	12"	N/A	12"	N/A	N/A	N/A	1 (TOP)	>6'-0" TO 7'-6"
	12"	4"	N/A	12"	12"	10"	12"	8"	12"	7 1/2"	12"	7"	12"	12"	1 (BOTTOM)	
	12"	N/A	N/A	N/A	12"	N/A	12"	N/A	12"	N/A	12"	N/A	12"	12"	2 (TOP)	
	12"	5"	N/A	12"	12"	10"	12"	8"	12"	7 1/2"	12"	7"	N/A	N/A	2 (BOTTOM)	
	12"	N/A	N/A	N/A	12"	N/A	12"	N/A	12"	N/A	12"	N/A	N/A	N/A	3 (TOP)	
	12"	4"	N/A	12"	12"	10"	12"	8"	12"	7 1/2"	12"	7"	N/A	N/A	3 (BOTTOM)	
	12"	N/A	N/A	N/A	12"	N/A	12"	N/A	12"	N/A	12"	N/A	N/A	N/A	4 (TOP)	
	12"	4"	N/A	12"	12"	10"	12"	8"	12"	7 1/2"	12"	7"	N/A	N/A	4 (BOTTOM)	
	12"	N/A	N/A	N/A	12"	N/A	12"	N/A	12"	N/A	12"	N/A	N/A	N/A	5 (TOP)	
	10 1/2"	N/A	N/A	7 1/2"	12"	5"	12"	4"	12"	4"	10 1/2"	4"	N/A	N/A	5 (BOTTOM)	
	11 1/2"	N/A	N/A	N/A	12"	N/A	12"	N/A	12"	N/A	10 1/2"	N/A	N/A	N/A	6 (TOP)	
	9"	N/A	N/A	N/A	12"	N/A	12"	N/A	11 1/2"	N/A	8"	N/A	N/A	N/A	6 (BOTTOM)	
7 1/2"	N/A	N/A	N/A	10 1/2"	N/A	11 1/2"	N/A	10"	N/A	7"	N/A	N/A	N/A	7 (TOP/BOTTOM)		
N/A	N/A	N/A	N/A	N/A	N/A	12"	8"	12"	6"	12"	7"	12"	12"	8 (TOP/BOTTOM)		

MAXIMUM A.S.D. DESIGN PRESSURE RATING (p.s.f.)	MAXIMUM ANCHORS SPACING FOR E. D. = 3 1/2" **														APPLICABLE TO SECTIONS # & ANY COMBINATION OF THEM	MAXIMUM PANEL LENGTH "L" (ft.)
	L.T.W. BUILDING				ELCO CONSTRUCTION PRODUCTS						DEWALT, INC		ALL POINTS			
	TAPCONS/MAXI-SET TAPCONS		RED HD SLEEVE		CRETE-FLEX SS4		MALE/FEMALE PANELMATE		MALE PANELMATE PLUS		CALK-IN		SOLID-SET			
	TO CONCRETE	TO BLOCK	TO CONCRETE	TO BLOCK	TO CONCRETE	TO BLOCK	TO CONCRETE	TO BLOCK	TO CONCRETE	TO BLOCK	TO CONCRETE	TO BLOCK	TO CONCRETE	TO BLOCK		
+66.0, -70.0	12"	N/A	N/A	N/A	12"	N/A	12"	N/A	12"	N/A	12"	N/A	N/A	N/A	1 (TOP)	>7'-6" TO 8'-6"
	12"	4"	N/A	12"	12"	9"	12"	7"	12"	6"	12"	6"	12"	12"	1 (BOTTOM)	
	12"	N/A	N/A	N/A	12"	N/A	12"	N/A	12"	N/A	12"	N/A	12"	12"	2 (TOP)	
	12"	4"	N/A	12"	12"	9"	12"	7"	12"	6"	12"	6"	N/A	N/A	2 (BOTTOM)	
	12"	N/A	N/A	N/A	12"	N/A	12"	N/A	12"	N/A	12"	N/A	N/A	N/A	3 (TOP)	
	12"	4"	N/A	12"	12"	9"	12"	7"	12"	6"	12"	6"	N/A	N/A	3 (BOTTOM)	
	12"	N/A	N/A	N/A	12"	N/A	12"	N/A	12"	N/A	12"	N/A	N/A	N/A	4 (TOP)	
	12"	4"	N/A	12"	12"	N/A	12"	7"	12"	6"	12"	6"	N/A	N/A	4 (BOTTOM)	
	12"	N/A	N/A	N/A	12"	N/A	12"	N/A	12"	N/A	12"	N/A	N/A	N/A	5 (TOP)	
	8"	N/A	N/A	6"	12"	N/A	11"	N/A	11"	3"	8"	3"	N/A	N/A	5 (BOTTOM)	
	10"	N/A	N/A	N/A	12"	N/A	12"	N/A	12"	N/A	9"	N/A	N/A	N/A	6 (TOP)	
	8"	N/A	N/A	N/A	12"	N/A	10"	N/A	10"	N/A	7"	N/A	N/A	N/A	6 (BOTTOM)	
7"	N/A	N/A	N/A	9"	N/A	10"	N/A	9"	N/A	6"	N/A	N/A	N/A	7 (TOP/BOTTOM)		
N/A	N/A	N/A	N/A	N/A	N/A	12"	7"	12"	6"	12"	6"	12"	12"	8 (TOP/BOTTOM)		

**MAXIMUM A.S.D. DESIGN PRESSURE RATING (p.s.f.) AND CORRESPONDING MAXIMUM ANCHOR SPACING SCHEDULE FOR INSTALLATIONS INTO CONCRETE AND CONCRETE BLOCK STRUCTURES \***

\*\* MAXIMUM ANCHOR SPACINGS ARE VALID FOR 3 1/2" EDGE DISTANCE. FOR E. D. LESS THAN 3 1/2", REDUCE ANCHOR SPACING BY MULTIPLYING SPACING SHOWN ON SCHEDULE BY THE FOLLOWING FACTORS. (NOTE : Min. E. D. FOR CALK-IN ANCHORS IS 2 1/2"). FOR THIS OPERATION TO BE POSSIBLE, REDUCED SPACING OBTAINED USING FACTOR SHALL NOT BE LESS THAN MINIMUM SPACING INDICATED FOR EACH ANCHOR TYPE AT ANCHORS LEGEND.

ACTUAL E. D.	FACTOR			
	TAPCON/ CRETE-FLEX SS4/ PANELMATES	CALK-IN	SOLID-SET	RED HD. SLEEVE
3"	-	.75	.78	1.00
2 1/2"	-	.50	-	1.00
2"	-	-	-	0.88
1 1/2"	.35	-	-	-

**ANCHORS LEGEND**

ANCHORS TYPE	ANCHOR MIN. SPACING
TAPCON/ PANELMATES	4.0"
CALK-IN	2.5"
SOLID-SET	3.5"
3/8"Ø RED HD. DYNABOLT SLEEVE	4.5"
CRETE FLEX SS4	6.0"

E. D. = EDGE DISTANCE

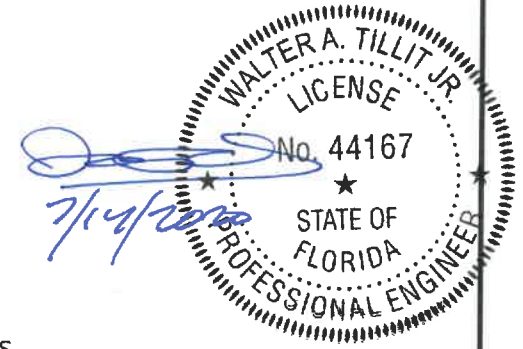

\*SEE NOTES ON SHEET 8 & 9 OF 9 FOR ANCHOR TYPES & SPACING FOR INSTALLATIONS INTO WOOD FRAME BUILDINGS.

© 2020 TILTECO, INC.

**TILTECO INC.**

TILLIT TESTING & ENGINEERING COMPANY  
6355 N.W. 36th St., Ste. 305, VIRGINIA GARDENS, FL 33166  
Phone : (305)871-1530 . Fax : (305)871-1531  
CA-0006719  
WALTER A. TILLIT Jr. P.E.  
FLORIDA Lic. # 44167

**FLORIDA BUILDING CODE (High Velocity Hurricane Zone)**

**0.030" THICK GALVANIZED BERTHA STEEL STORM PANEL (2.25" DEEP)**

**EASTERN METAL SUPPLY, INC**  
4268 WEST ROADS DRIVE  
WEST PALM BEACH, FL 33407  
PHONE: (561)533-6061  
FAX: (561)588-4780

M.P.  
DRAWN BY:  
7/9/2020  
DATE:  
**20-185**  
DRAWING No  
SHEET 7 OF 9

REV. NO	DESCRIPTION	DATE	REV. No	DESCRIPTION	DATE
1	OLD 17-098	7/9/2020	3		
2			4		



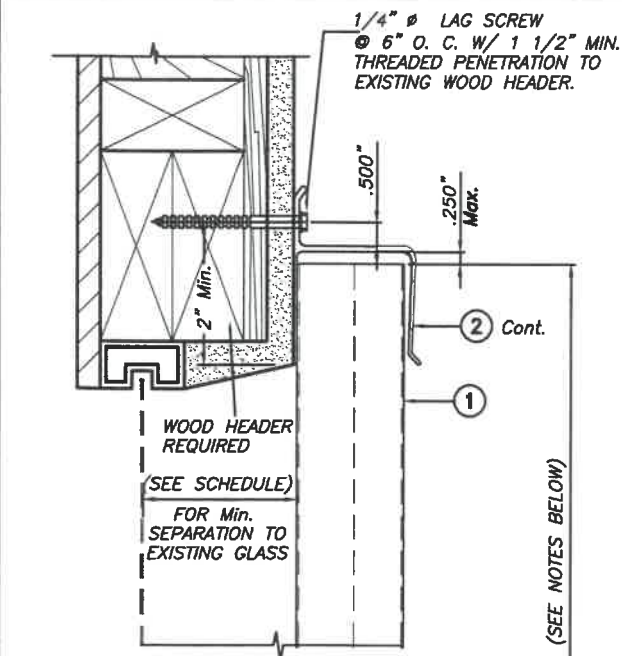

**ALTERNATIVE 1**

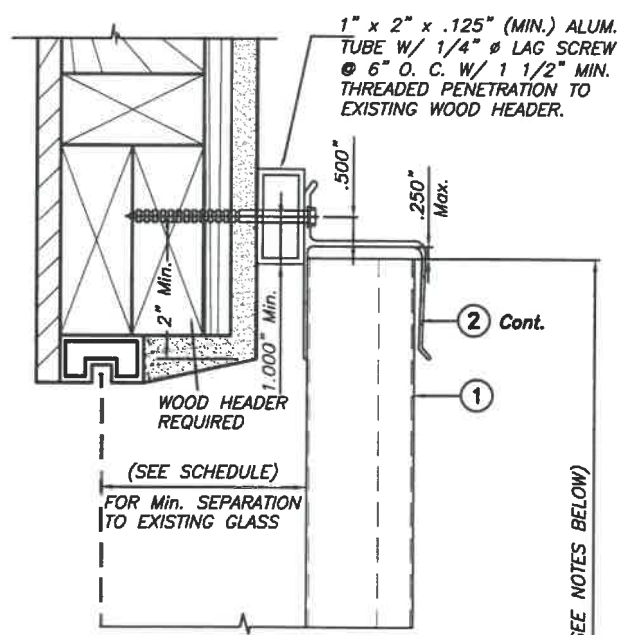

**ALTERNATIVE 3**

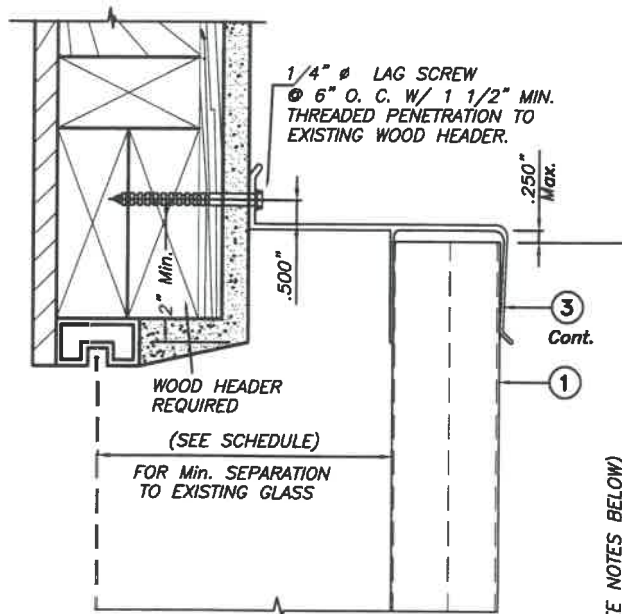

**ALTERNATIVE 5**

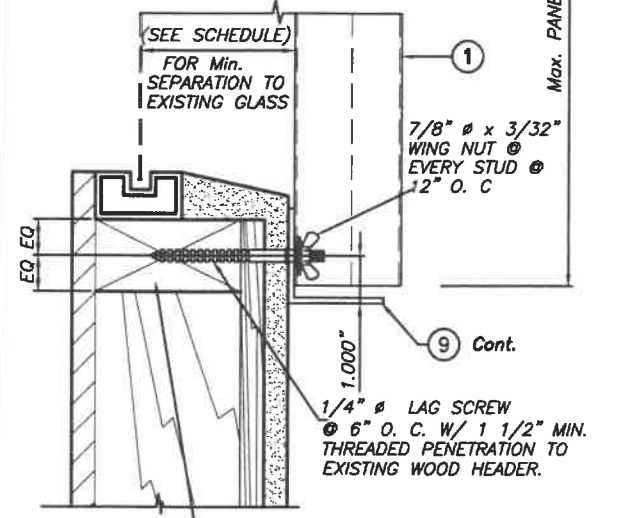

**ALTERNATIVE 2**

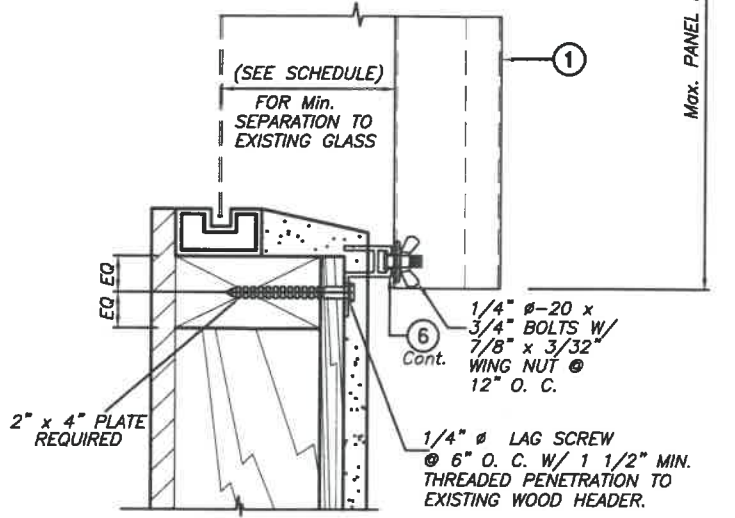

**ALTERNATIVE 4**

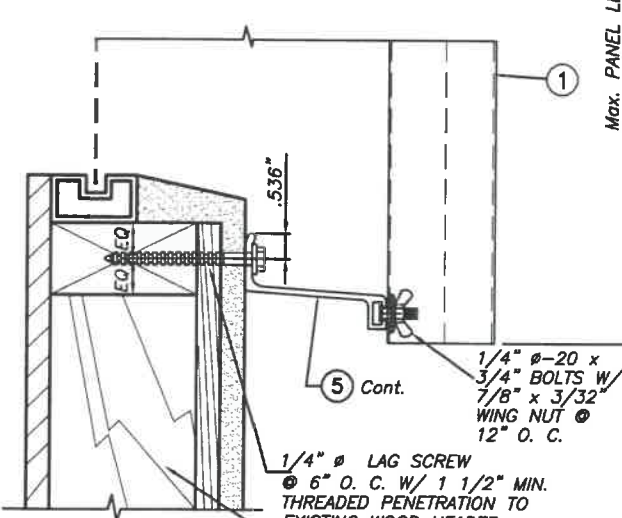

**ALTERNATIVE 6**

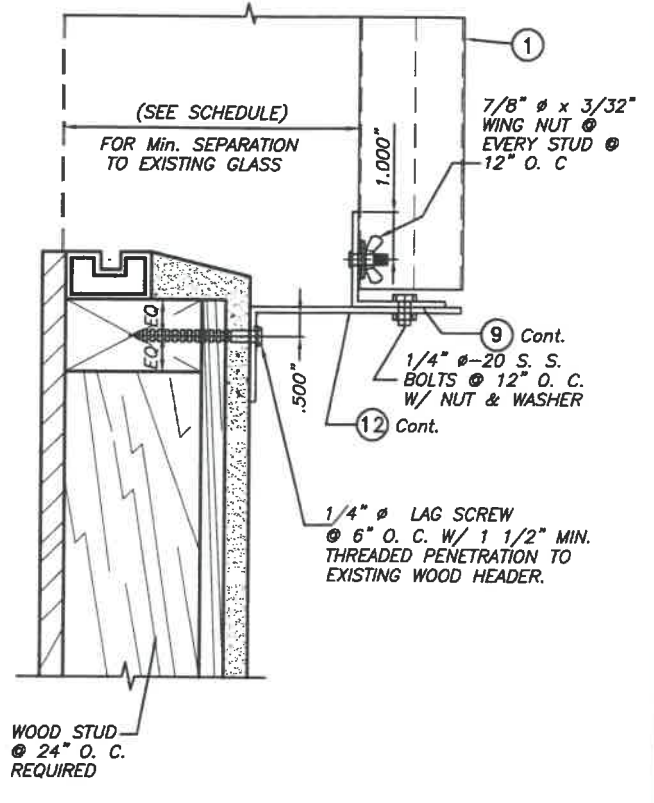

**ALTERNATIVE 7**

**WALL MOUNTING INSTALLATIONS**

**SECTIONS A**

SCALE : 1/4" = 1"

**INSTALLATION DETAILS ON EXISTING WOOD BUILDINGS**

**NOTE FOR COMBINATION OF SECTIONS:**

WALL MOUNTING SECTIONS CAN BE COMBINED  
 IN ANY WAY TO SUIT ANY INSTALLATION.

**NOTES:**

- INSTALLATIONS ARE ONLY VALID FOR MAX. A.S.D. DESIGN PRESSURE RATING AND MAX. PANEL LENGTHS AS PER SCHEDULE ON SHEET 4 OF 9
- FOR NEW WOOD FRAME CONSTRUCTION: WOOD MEMBERS TO BE SOUTHERN PINE No. 2, W/ SPECIFIC DENSITY OF 0.55 OR EQUAL.

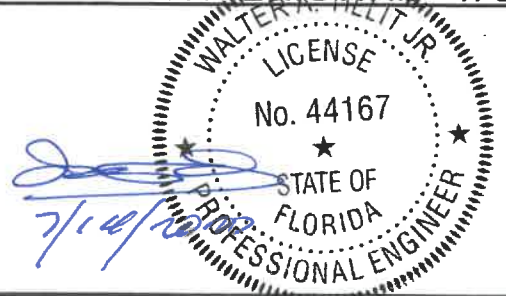

© 2020 TILTECO, INC.

**TILTECO inc.**

TILLIT TESTING & ENGINEERING COMPANY  
 6355 N.W. 36th St., Ste. 305, VIRGINIA GARDENS, FL 33166  
 Phone : (305)871-1530 . Fax : (305)871-1531  
 CA-0006719  
 WALTER A. TILLIT Jr. P.E.  
 FLORIDA Lic. # 44167

**FLORIDA BUILDING CODE (High Velocity Hurricane Zone)**

**0.030" THICK GALVANIZED BERTHA STEEL  
 STORM PANEL (2.25" DEEP)**

**EASTERN METAL SUPPLY, INC**

4268 WEST ROADS DRIVE  
 WEST PALM BEACH, FL 33407  
 PHONE: (561)533-6061  
 FAX: (561)588-4780

M.P.  
 DRAWN BY:  
 7/9/2020  
 DATE:

**20-185**

DRAWING No

REV. NO	DESCRIPTION	DATE	REV. No	DESCRIPTION	DATE
1	OLD 17-088	7/9/2020	3		
2			4		

SHEET 8 OF 9

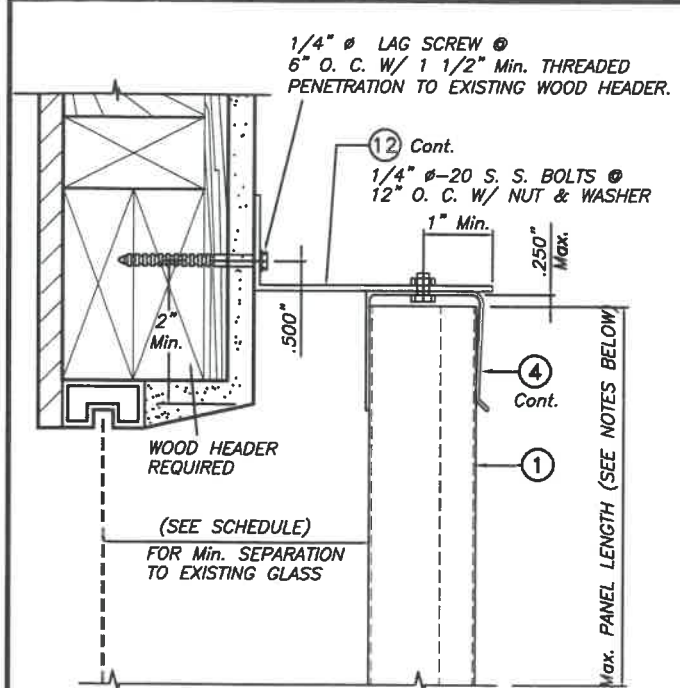

**ALTERNATIVE 8**

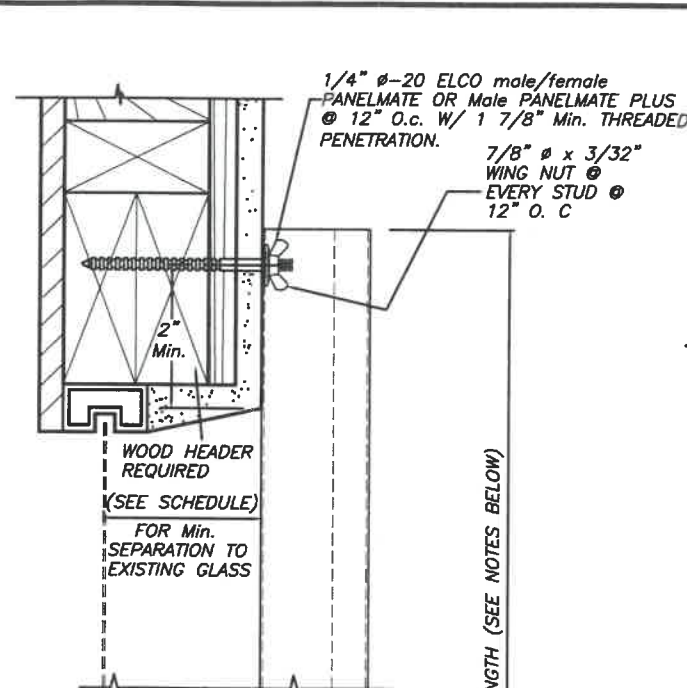

**ALTERNATIVE 10**

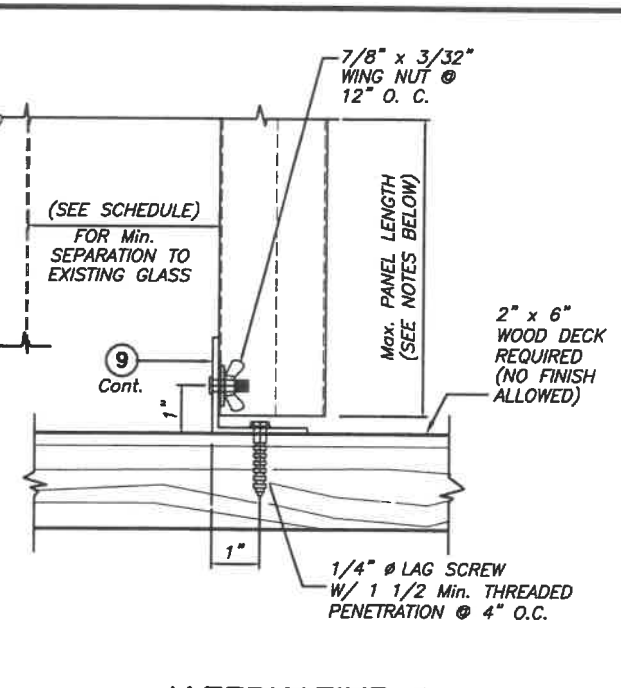

**ALTERNATIVE 1**

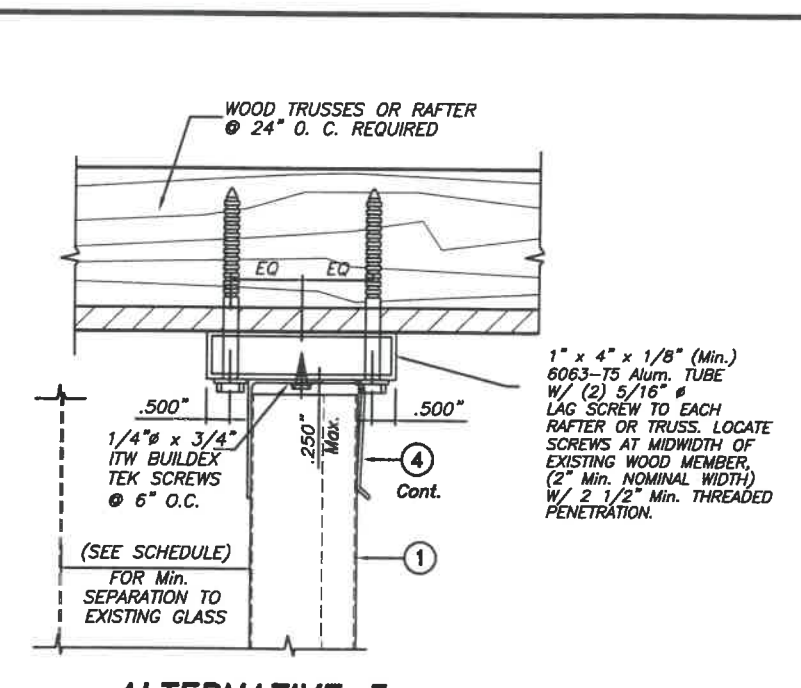

**ALTERNATIVE 3**

(Max. DESIGN LOAD= ± 61.0 psf  
Max. PANEL LOAD= 8'-0")

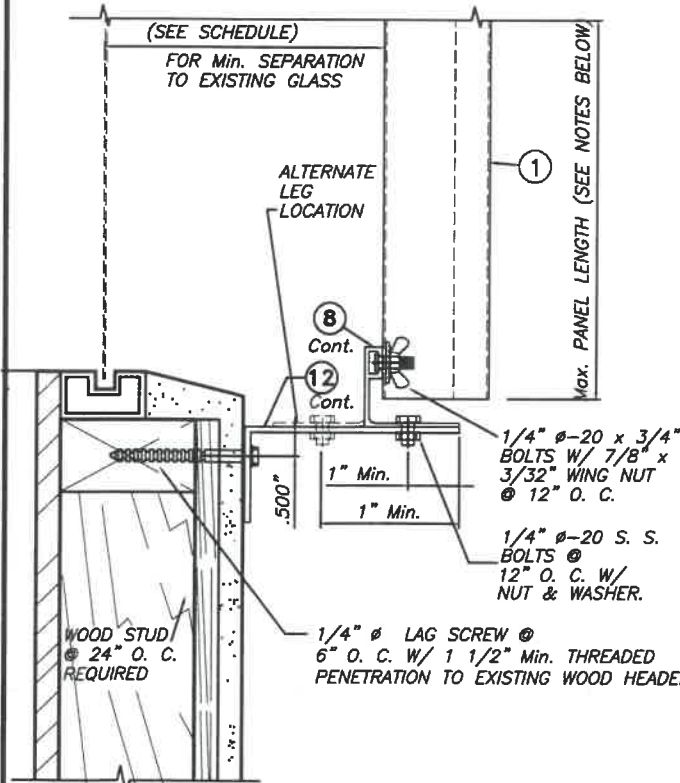

**ALTERNATIVE 9**

**WALL MOUNTING INSTALLATIONS**

**SECTIONS A**

SCALE : 1/4" = 1"

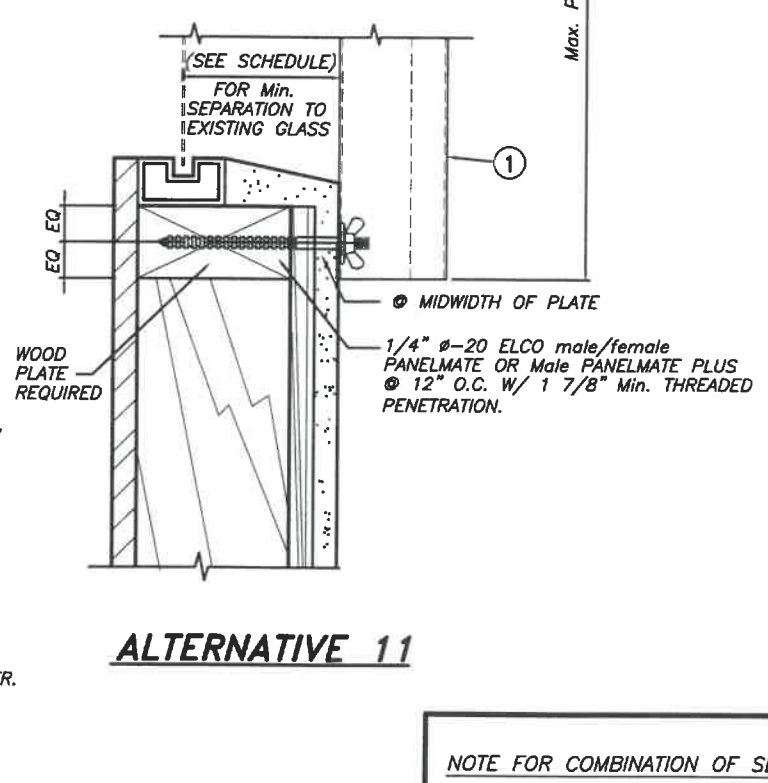

**ALTERNATIVE 11**

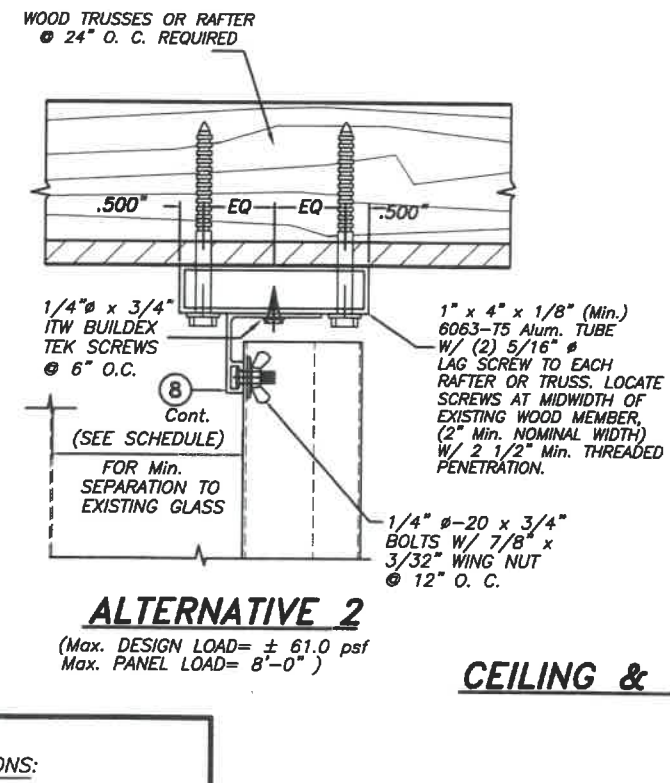

**ALTERNATIVE 2**

(Max. DESIGN LOAD= ± 61.0 psf  
Max. PANEL LOAD= 8'-0")

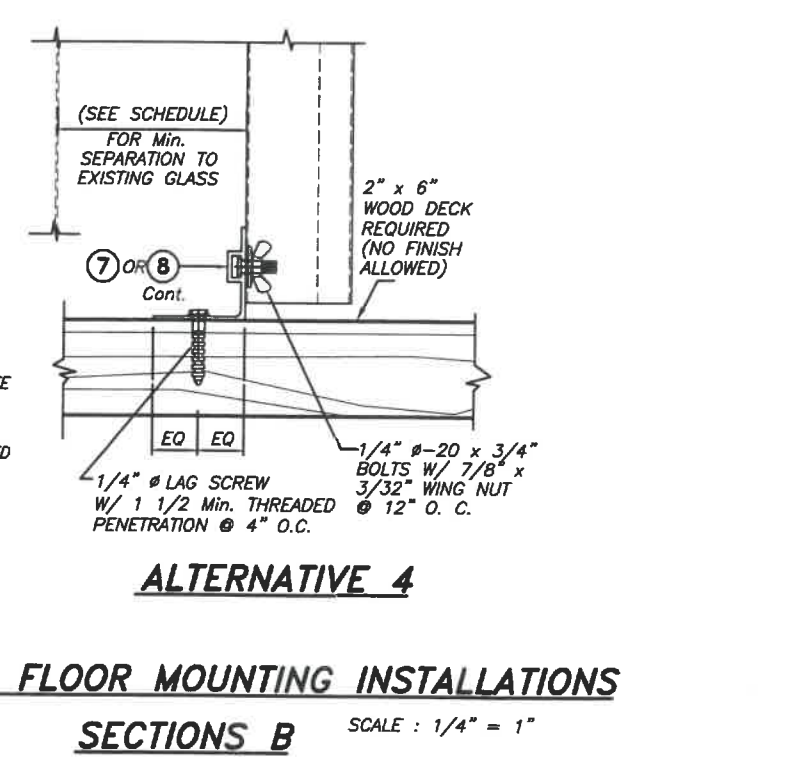

**ALTERNATIVE 4**

**CEILING & FLOOR MOUNTING INSTALLATIONS**

**SECTIONS B**

SCALE : 1/4" = 1"

NOTE FOR COMBINATION OF SECTIONS:  
FLOOR/ WALL/ CEILING MOUNTING SECTIONS CAN BE COMBINED IN ANY WAY TO SUIT ANY INSTALLATION.

**INSTALLATION DETAILS ON EXISTING WOOD BUILDINGS**

NOTES:  
1. INSTALLATIONS ARE ONLY VALID FOR MAX. A.S.D. DESIGN PRESSURE RATING AND MAX. PANEL LENGTHS AS PER SCHEDULE ON SHEET 4 OF 9, EXCEPT THAT FOR ALTERNATIVES 2 AND 3 A Max. PANEL LENGTH OF 8'-0" AND A Max. DESIGN LOAD OF ± 61.0 PSF SHALL BE USED.  
2. FOR NEW WOOD FRAME CONSTRUCTION: WOOD MEMBERS TO BE SOUTHERN PINE No. 2, W/ SPECIFIC DENSITY OF 0.55 OR EQUAL.

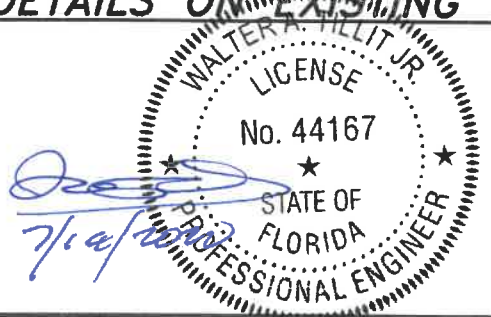

© 2020 TILTECO, INC.

**TILTECO INC.**

TILLIT TESTING & ENGINEERING COMPANY  
6355 N.W. 36th St., Ste. 305, VIRGINIA GARDENS, FL 33166  
Phone : (305)871-1530 . Fax : (305)871-1531  
CA-0006719  
WALTER A. TILLIT Jr. P.E.  
FLORIDA Lic. # 44167

**FLORIDA BUILDING CODE (High Velocity Hurricane Zone)**

**0.030" THICK GALVANIZED BERTHA STEEL STORM PANEL (2.25" DEEP)**

**EASTERN METAL SUPPLY, INC**

4268 WEST ROADS DRIVE  
WEST PALM BEACH, FL 33407  
PHONE: (561)533-6081  
FAX: (561)588-4780

M.P.  
DRAWN BY:  
7/9/2020  
DATE:

**20-185**  
DRAWING No

REV. NO	DESCRIPTION	DATE	REV. No	DESCRIPTION	DATE
1	OLD 17-08B	7/9/2020	3		
2			4		